



THOR
Tool and Die Company

Manufacturing Precision for the Tooling Professional

Thor Model 2018 Hand Operated Turret Punch Press

Thor Universal Turret Punch Press Is Tailored to Give You Tooling Choices.

Engineered for Versatility

Thor's Model 2018 is designed to accommodate five different tooling styles—Roper Whitney, W.A. Whitney, Di-Acro, Behrens, and Wiedemann. So you can employ your existing tooling inventory to utilize your punch press to its fullest potential. An 18 station turret layout—11 small, 4 medium, 3 large—and a sizeable 2" punching capacity through 12 gauge mild steel provides your press operator a variety of performance options that command ease with any job.

Built for Reliability and Safety

Thor's Model 2018 is manufactured to give you years of reliable service. Twin steel frame plates offer unit strength. Moving parts are bearing supported and wearing parts are made of hardened steel. Thor's unique "ram-loc" safety feature prevents any ram movement until the turret is securely locked into punching position.

Operated with Ease

The Model 2018 functions with your press operator in mind. A 20" throat depth allows for handling 40" material. The synchronized punch and die turret rotates in unison. Individual die shoes and punch holders—keyed for 0° and 90° tooling indexing—enable fast die changes and easy alignment. The self-stripping turret automatically strips material from the punches as the ram cycles upward. For stripping lighter gauge materials, optional individual metal stripper plates can be inserted into the milled pocket located under each punch station.

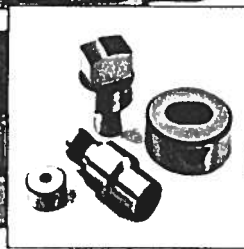

Roper Whitney

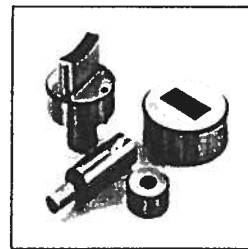

W.A. Whitney

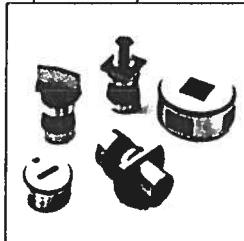

Di-Acro



Behrens

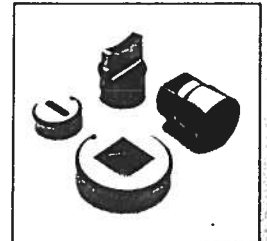

Wiedemann

Thor's 2018 Universal Turret Model 2018 turret accepts five different tooling styles. Choose from Roper Whitney Single Station, W.A. Whitney 28XX, Di-Acro 902/903, 906, 914 Series, Behrens 212, or Wiedemann 112 styles.

Product Accessories

To help you utilize the Thor Model 2018 to its maximum capabilities, Thor offers as optional equipment a floor stand and a series of worktables. The Standard Worktable, Model WTS-20, features adjustable side, front, and back gauges for positioning material; the Micrometer Worktable, Model WTM-20, provides precision gauging with accurate X and Y axis positioning; and the Floor Stand, Model FS-20, affords the press operator two shelves for spare tooling and storage.

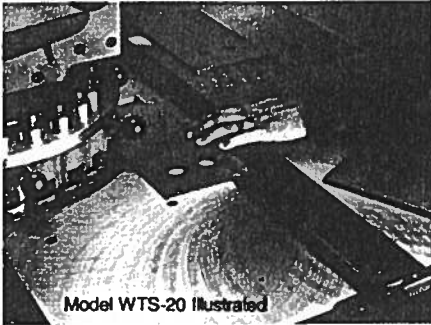

Model WTS-20 Illustrated

Tooling

Special tooling packages are available to complement the Model 2018. Precision machined from tool steel, Thor punches and dies are hardened and ground to exacting tolerances. Thor offers five different styles of tool holders, machined to fit the tooling of your choice. Refer to our price list for more details on tooling packages and tool holders.

About the Company

Thor Tool and Die Company manufactures superior quality tooling products for the sheet metal fabrication industry. In operation since 1944, Thor has built and maintained an unparalleled reputation for customer service and product reliability that is respected industry-wide. Thor's punch presses represent the Company's product philosophy: Combining design practicality with precision manufacturing, all at an affordable price. We take great satisfaction in our products and our service. You can depend on us.

Thor Model 2018 Accessory Equipment Is Designed to Enhance Your Productivity.

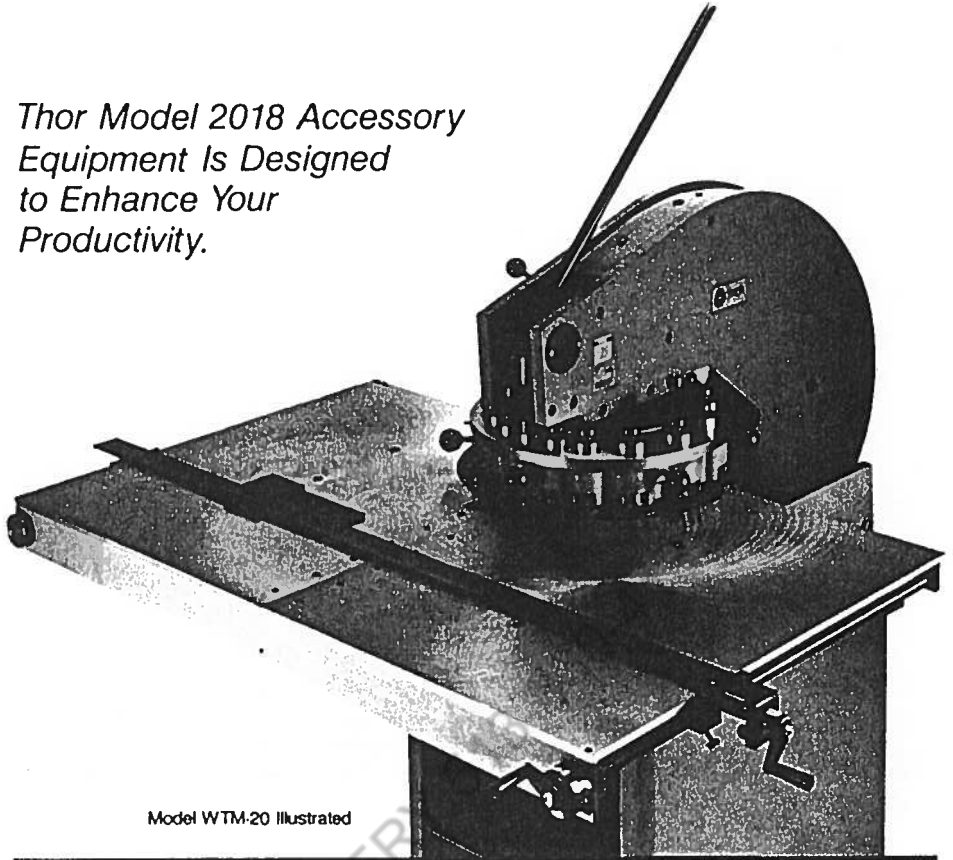

Model WTM-20 Illustrated

Specifications

Thor Model 2018 is manufactured in USA

PUNCH PRESS	MODEL 2018
Throat Depth	20" (508mm)
Turret Stations	18 Total (11 small, 4 medium, 3 large)
Maximum Material Capacity	2" (50.8 mm) Diameter hole in 12 gauge (2.7 mm) mild steel (with proper punch shear and die clearance).
Clearance-die to stripper	1/4" (6.4 mm)
Ram Stroke	5/8" (16 mm)
Press Width	19" (483 mm)
Press Length	39" (991 mm)
Press Height, with handle	47" (1194 mm)
Mounting	Work Bench or Floor Stand
Net Weight	840 # (378 kg)
Shipping Weight	910 # (410 kg)

Specifications for the Model 2018 Turret Punch Press, Accessories and Tooling are subject to change without notice.

Punches and Dies are available in fractional, decimal or metric sizes with standard or special shapes. They are normally shipped within 5 to 7 working days. For tooling prices, see the current Thor 2018 Tooling Price List.

ACCESSORIES	MODEL WTS-20	MODEL WTM-20
WORK TABLES		
Table Dimensions	3/8" (9.5 mm) thick x 31-1/2" (800mm) deep x 48" (1219 mm) long	
Net Weight	170 # (77 kg)	190 # (86 kg)
Shipping Weight	245 # (110 kg)	265 # (120 kg)

All Thor table tops are constructed of heavy duty, thick steel plates, stress relieved and precision ground to prevent warping and insure flatness. Thor work tables come equipped with necessary mounting hardware and a comprehensive instruction booklet.

FLOOR STAND	MODEL FS-20
Stand Dimensions	23" (584 mm) wide x 28" (711 mm) deep x 28-1/2" (724 mm) high
Net Weight	275 # (124 kg)
Shipping Weight	325 # (147 kg)



Manufactured by
THOR
Tool and Die Company

865 Estabrook Street
San Leandro, CA 94577-3497 USA
(415) 357-6777
FAX: 415/351-5123

Not affiliated with Thor Power Tool Company

Distributed by

Call Toll Free:
CA: 800/FOR-THOR
USA: 800/222-THOR

Printed in USA 10 87

<u>Turret Features</u>	<u>Di-Acro Model 18</u>	<u>Rotex Model 18-A</u>	<u>THOR Model 2018</u>	<u>Comments</u>
1. Turret Stations:				Murphy's Law States: "When you have only one large station to use, you need two." THOR gives you <u>three</u> , just in case. <i>THOR gives you more. . .again!</i>
Small	12	9	11	
Medium	5	9, one each in sizes ranging from 5/8 to 2"	4	
<u>Large</u>	<u>1</u>		<u>3</u>	
Total Stations	18	18	18	
2. Synchronized Punch and Die Turret Rotation.	STANDARD	OPTIONAL	STANDARD	Synchronized Turret that rotates punches and dies together is not only better, it's safer. Synchronization avoids operator errors like stuffing a <i>big</i> one into a <i>little</i> one or fitting a <i>square</i> peg into a <i>round</i> hole.
3. Individual Punch Holders.	YES	YES	YES	
4. Individual Die Shoes.	YES	NO	YES	THOR provides conventional tooling alignment procedures.
5. Punch and Die Holders Keyed for 0 and 90 Degree Shaped Tooling Indexing, as Standard.	YES	NO	YES	
6. Removable Stripper Plates.	YES	NO	YES	THOR'S fitted stripper plates are a must for stripping thin materials from punches.
7. Where is the Punch Press Manufactured?	USA	USA	USA	
8. Approximate Shipping Weight	900*	400*	850*	Look at it this way. . . with THOR'S shipping weight at about 850*, Di-Acro's press is more expensive to ship and Rotex's press is easier to steal!

Call, FAX or Write today for more information . . . You'll be Impressed!



THOR Tool and Die Company
865 Estabrook Street
San Leandro, CA 94577-3497 USA
415/357-6777

CA: 800/367-8467
USA: 800/222-8467
FAX: 415/351-5123