

MODEL 36/52 FOOT SHEARS

TENNSMITH  [®] USA



OPERATION, PARTS & MAINTENANCE MANUAL
SMITHVILLE ROAD: McMINNVILLE, TENNESSEE 37110 USA-931/934-2211

MODEL 36/52 FOOT SHEARS PARTS LIST

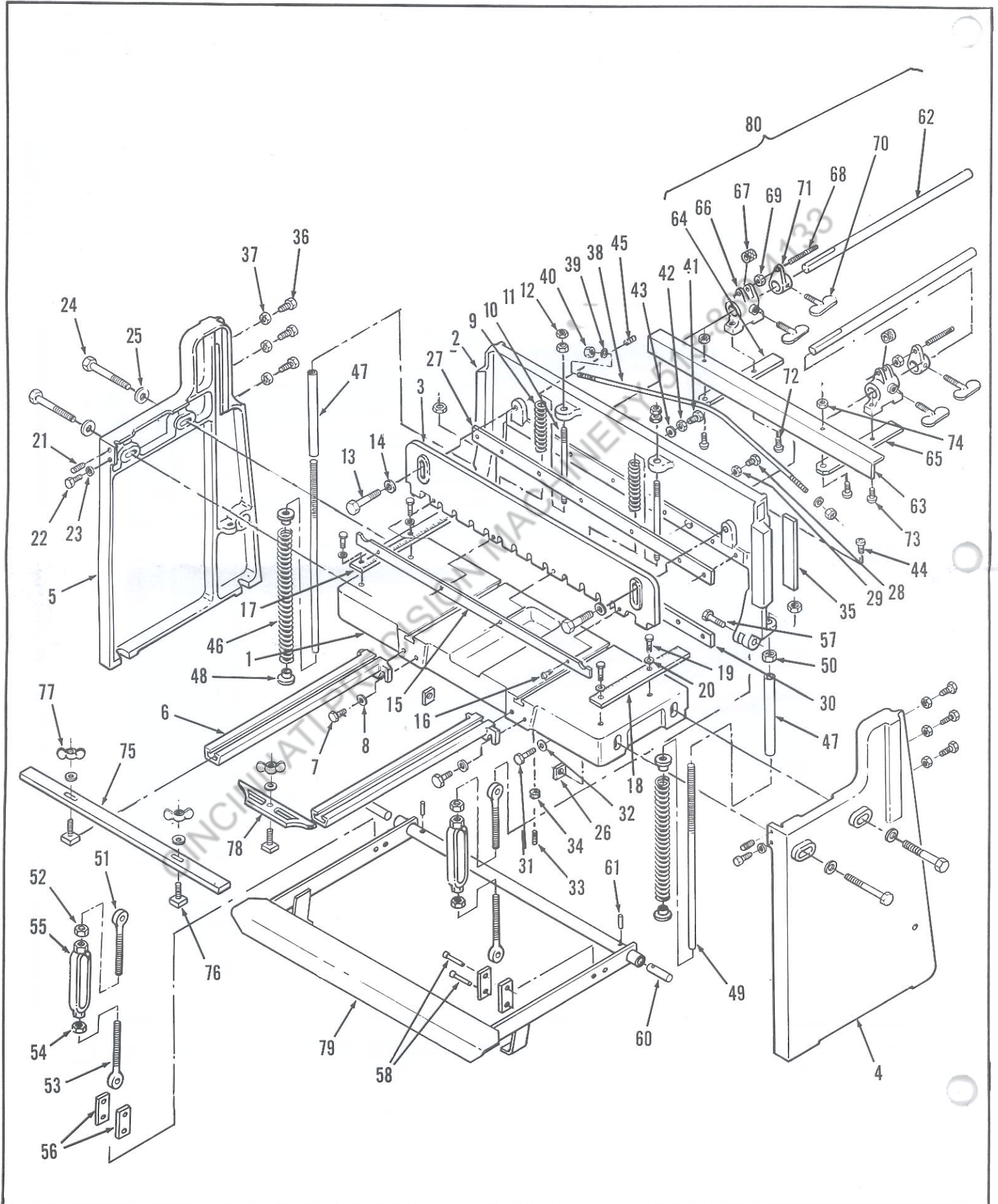

PARTS LIST

INDEX NO.	36	52	DESCRIPTION	QTY.
1	10101	10151	TABLE	1
2	10102	10152	CUTTER BAR	1
3	10103	10153	HOLDDOWN	1
4	10051	10051	R.H. SIDE PANEL	1
5	10052	10052	L.H. SIDE PANEL	1
6	10053	10053	FRONT ARM EXT.	2
7	05055	05055	SCREW, FRONT ARM EXT.	4
8	05673	05673	WASHER, FRONT ARM EXT.	4
9	10054	10054	SPRING, HOLDDOWN	2
10	10111	10164	STUD, HOLDDOWN SPRING	2
11	05880	05880	NUT, HOLDDOWN STUD	2
12	05907	05907	CAP NUT, HOLDDOWN STUD	2
13	05060	05060	SCREW, HOLDDOWN	2
14	05673	05673	WASHER, HOLDDOWN SCREW	2
15	10104	10154	FINGER GUARD	1
16	05396	05396	SCREW, FINGER GUARD	4/5
17	10055	10055	SCALE, L.H. TABLE	1
18	10056	10056	SCALE, R.H. TABLE	1
19	05021	05021	SCREW, TABLE SCALE	4
20	05639	05639	WASHER, TABLE SCREW	4
21	05327	05327	SET SCREW, TABLE ADJ.	2
22	05035	05035	SCREW, TABLE LOCK	2
23	05670	05670	WASHER, TABLE LOCK SCREW	2
24	05075	05075	BOLT, TABLE	4
25	05676	05676	WASHER, TABLE BOLT	4
26	05925	05925	NUT, TABLE	4
27	10105	10155	KNIFE, UPPER	1
28	05033	05033	SCREW, UPPER KNIFE	7/9
29	05670	05670	WASHER, UPPER KNIFE	14/18
30	10106	10156	KNIFE, LOWER	1
31	05035	05035	SCREW, LOWER KNIFE	6/8
32	05670	05670	WASHER, LOWER KNIFE	12/16
33	05246	05246	SET SCREW, LOWER KNIFE ADJ.	6/8
34	05759	05759	NUT, LOWER KNIFE ADJ.	6/8
35	10064	10064	SHIM, C' BAR	2
36	05249	05249	SCREW, C' BAR SHIM	6
37	05762	05762	NUT, C' BAR SHIM SCREW LOCK	6
38	10107	10157	STRAIGHTENER ROD, C' BAR	1
39	05673	05676	WASHER, STRAIGHTENER ROD	2
40	05787	05790	NUT, STRAIGHTENER ROD	2
41	10112	10165	ADJ. SCREW, STRAIGHTENER ROD	1
42	05790	05790	NUT, ADJ. SCREW	1
43	05676	05676	WASHER, ADJ. SCREW	1
44	05331	05331	SET SCREW, BACKGAUGE ROD	2
45	05331	05331	SET SCREW, HOLDDOWN LOCK	2
46	10302	10302	SPRING, FOOT PEDAL	2
47	15053	15053	SPRING GUIDE	2
48	15057	15057	CAP, SPRING	4
49	15055	15055	STUD, SPRING	2
50	05787	05787	NUT, SPRING STUD	8
51	10069	10069	LINKAGE BOLT, C' BAR	2
52	05827	05827	NUT, LINKAGE BOLT, C' BAR	2
53	10067	10067	LINKAGE BOLT, FOOT PEDAL	2
54	05826	05826	NUT, LINKAGE BOLT, FOOT PEDAL	2
55	10071	10071	TURNBUCKLE	2
56	10073	10073	LINK, PEDAL	4
57	06354	06354	PIN, LINKAGE, MOUNTING	2
58	06353	06353	PIN, PEDAL LINK	4
59	06158	06158	KEY, PEDAL LINK PIN	4
60	15059	15059	PIN, PEDAL BAR	2
61	06131	06131	SPLIT PIN, PEDAL BAR	2
62	10058	10058	ROD, BACKGAUGE	2
63	10110	10163	STOP, BACKGAUGE	1
64	10065	10065	R. EXT. BAR, BACKGAUGE	1
65	10066	10066	L. EXT. BAR, BACKGAUGE	1
66	10059	10059	ADJ. BLOCK, BACKGAUGE	2
67	10060	10060	ADJ. DIAL, BACKGAUGE	2
68	10075	10075	ADJ. SCREW, BACKGAUGE	2
69	05762	05762	NUT, ADJ. SCREW	2
70	10061	10061	LOCK SCREW, BACKGAUGE	4
71	10062	10062	ADJ. BRKT. BACKGAUGE	2
72	05027	05027	SCREW, EXT. BAR	2
73	05325	05325	SWIVEL BOLT	3
74	10109	05765	NUT, SWIVEL BOLT	2
75	10159	10159	STOP, FRONT MATERIAL	1
76	10074	10074	"T"-NUT	3
77	05938	05938	WING NUT, "T"-NUT	3
78	10063	10063	BEVEL GAUGE	1
79	14040	15051	PEDAL ASSEMBLY	1
80	10108	10158	BACKGAUGE ASSEMBLY	1

FOREWORD

This manual has been prepared for the owner and operators of the TENNSMITH Model 36 and 52 shear.

Its purpose, aside from operation instruction, is to promote safety through the use of accepted operating procedures.

Read all instructions thoroughly before operating your shear.

Also contained in this manual is the parts list for your shear. It is recommended that only TENNSMITH or factory authorized parts be used for replacement parts.

WARRANTY

Your shear has a three year limited warranty from date of purchase. The terms of the warranty are stated on the warranty registration card shipped with your machine. Please complete and return this card to activate your warranty.

SAFETY INSTRUCTIONS

1. Know the safety and operating instructions contained in this brochure. Become familiar with and understand the hazards and limitations of this shear. Always practice safety.
2. Wear approved eye safety protection, such as glasses, goggles, etc., when operating the shear to protect your eyes.
3. Protective type footwear should be worn, and jewelry, such as rings, watches, etc., should be removed when operating the shear.
4. Do not remove the guard. It is a protection device. Keep holddown clearance to the minimum gap required to feed material.
5. Always keep hands clear of blade.
6. Do not misuse the shear by using it for other than its intended purpose.
7. Keep the work area clear and clean to avoid tripping or slipping.

RECEIVING THE SHEAR

Examine the shear and accessories package for evidence of damage sustained in transit. Any damage should be reported to your distributor immediately.

INSTALLING THE SHEAR

REMOVE THE SHEAR FROM SHIPPING SKID. Locate the shear in a well lighted area on a solid level floor.

Use lag screws or bolts with expandable shields or similar holding devices through mounting feet, located on the bottom of the side panels.

Place an accurate machinist level on the table top, and check the level of the machine in both directions. Use metal shims between floor and the shear mounting surface to adjust the level. After the machine is level, tighten the mounting bolts.

Periodically, recheck the unit for levelness.

NOTE: Superior performance will result from a properly leveled shear.

Never attempt to shear any material which would be less than a 1/2" cut across the full length of the table under full capacity.

BLADE GAP ADJUSTMENT

At the factory, the blades were set to a .002 clearance. This was achieved using a piece of shim stock. However, if this is unavailable, the thickness of news print will approximate this dimension.

To begin, loosen the four bolts (24) securing the table (1) to the side panels (4, 5). Pull the table towards you and depress the foot pedal (79) fully. Standing on the pedal, start on the left hand side (facing) of the shear by snugging the table bolts. Next, insert the shim stock between the upper and lower blades. Tighten the table adjusting screw (21) until the shim is held fast between the blades. Then, keeping upward tension on the shim stock, progressively tighten the table locking screw (22) until the shim stock is freed of pressure and can be removed. Retighten the table bolts and repeat the procedure on the opposite side of the shear.

After completing alignment, check the entire length of the blades for proper clearance using your shim stock. You may find that you either have too much or not enough clearance in the center of the blades. This adjustment is accomplished by increasing or decreasing pressure on the bow adjustment bolt (41) located at the rear of the cutter bar.

NOTE: A properly aligned shear will produce a scissor like sound when the blades transcend and will leave a minimal burr on sheared stock.

CUTTER BAR ADJUSTMENT

The cutter bar (2) should move freely throughout its range of travel without binding. This should be the case with a new shear. If the shear does bind, recheck for levelness.

The gibbs should be adjusted for snug yet nonbinding movement. To accomplish this, loosen all six gibb screws (36). Beginning at the right hand side of shear, depress foot pedal fully and lock the center gibb screw so that cutter bar remains down. Then, gradually loosen the screw until the cutter bar returns to its upright position. Proceed to back the screw off an additional quarter turn and lock the jam nut (37) in place. Continue by repeating this procedure for the remaining gibb screws.

Cutter bar lift is controlled by the amount of pressure exerted by the pedal springs (46). Appropriate tension was applied to the springs at the factory. However, over a period of years the springs may fatigue slightly and require additional compression.

OPERATION INSTRUCTIONS

The capacity of the Model 36 or 52 shear is 16 gauge mild steel.

The chart (Figure 1) should be used as an approximate material conversion comparison to show equivalent capacities of material other than mild steel. Do not exceed the capacity of this shear.

Mild Steel Capacity	20 Ga.	18 Ga.	16 Ga.
FERROUS METALS			
Iron-dead soft	20 Ga.	18 Ga.	16 Ga.
Steel-low carbon			
H.R.	20 Ga.	18 Ga.	16 Ga.
low carbon C.R.	20 Ga.	18 Ga.	16 Ga.
40°-50°	24 Ga.	22 Ga.	20 Ga.
carbon H.R.			
1074, 1095 C.R.	24 Ga.	22 Ga.	20 Ga.
Annealed spring steel			
low carbon C.R. HARD	22 Ga.	20 Ga.	18 Ga.
Stainless annealed	24 Ga.	22 Ga.	20 Ga.
Mild Steel Capacity	20 Ga.	18 Ga.	16 Ga.
NON-FERROUS METALS			
Aluminum			
1100-0, 2024-0	.068	.090	.120
1100-H16			
2024-T3, 5052-H34	.048	.063	.090
6061-T6, 7075-T4			
Copper and alloys			
electrolytic copper	18 Ga.	16 Ga.	14 Ga.
bronze commercial	18 Ga.	16 Ga.	14 Ga.
brass 70-30	18 Ga.	16 Ga.	14 Ga.
Nickel alloys			
Inconel 600	24 Ga.	22 Ga.	20 Ga.
Monel R405			
Nickel 200A annealed			
Zinc, as rolled	20 Ga.	18 Ga.	16 Ga.
Mild Steel Capacity	20 Ga.	18 Ga.	16 Ga.
OTHER MATERIALS			
Plastics			
ABS compounds	.120	.150	.200
polycarbonate	.075	.105	.125
Printed Circuit Boards			
copper-clad epoxy laminate	.086	.115	.150
APPROXIMATE GAUGE EQUIVALENTS			
Gauge	20	18	16
inches	.036	.048	.060
mm's	.91	1.22	1.60

FIGURE 1

LINKAGE ADJUSTMENT

The linkage on your TENNSMITH shear is comprised of two turnbuckle assemblies (55). Rotation of the turnbuckles is the means by which blade rake and pedal height is set. There should be no need for this adjustment on a new shear.

The pitch or rake of the top blade on both the 52 and 36 shear is approximately .030 per linear inch. To attain this setting, mark a pencil mark on the shear bed at two inches from the R.H. edge of the table. Next, measure over 48 inches for the Model 52 and 36 inches on the Model 36 and make another mark. Starting at the R.H. side (facing the machine) at the designated mark on the table, rotate the turnbuckle until the distance between the top and bottom blades is approximately $\frac{3}{8}$ of an inch. Once the above setting is attained, tighten the top gibb screw on that side to secure the dimension. At the opposing end, repeat the procedure allowing 1 $\frac{3}{4}$ inches clearance for the 52 and 1 $\frac{1}{2}$ inches on the 36 shear. Blade rake should now be correct. Remember to reset appropriate gibb clearance. (NOTE: Cutter bar lift is not controlled by a positive stop. The actual clearance between the upper and lower blade will vary slightly due to spring tension. However, blade rake will not change once it is set.)

Foot pedal lift is similarly adjusted through turnbuckle rotation. Lift adjustment serves two purposes. It facilitates an acceptable working height for pedal operation and ensures proper blade penetration across the working length of the shear. First, secure the top gibb screw on each side of the shear to maintain blade rake. Then, adjust the foot pedal to what would appear to be an appropriate return lift. (NOTE: When gibbs are loosened a slight degree of additional lift will be achieved.) Once you have an approximate setting, loosen the top two gibb screws and depress the foot pedal. Examine the L.H. side of the machine to determine that the top blade does indeed transcend the bottom blade by at least $\frac{1}{8}$ of an inch. If this is the case, tighten the jam nuts on the turnbuckles being certain not to move the turnbuckles themselves or your rake alignment will be distorted. Should the penetration be less than satisfactory, retighten the gibbs to maintain rake and adjust the turnbuckles for additional pedal lift. This will allow for deeper penetration. Reverse the procedure for opposite circumstances.

When adjusting turnbuckles, be certain that both linkages have the same amount of tension applied to each. That is, if one turnbuckle has more play or lost motion in it than the other, it should be readjusted accordingly.

As an additional point, it should be noted that there are two leverage holes provided in the foot pedal arms for connecting the linkage assembly. Your shear was shipped with the pins in the uppermost holes and should supply adequate leverage for shearing material within the machine's rated capacity. However, if you will be operating the shear at it's peak capacity, moving the linkage pins to the lower of the two holes will give you some additional leverage.

HOLDDOWN ADJUSTMENT

CAUTION: THIS SHEAR SHOULD NOT BE OPERATED WITHOUT THE HOLDDOWN IN PLACE AND PROPERLY ALIGNED. The holddown (3) is designed to engage the material before the blades yet allow only minimal clearance between the guard's feet and table surface. The gap between the holddown and table is controlled by turning the nut on the holddown studs (11). Clockwise rotation will increase clearance, counter clockwise turns will decrease the gap.

The guard should be held snug against the milled pads on the cutter bar and not feel loose. You must be careful, however, that the holddown screws (13) are not so tight as to bind the guard when the cutter bar is depressed. Properly aligned, the screws will snug but still allow rotation of the holddown screw washers (14). At the rear of the cutter bar you will find two tapped holes wherein holddown jam screws (45) are located. Once you have applied proper tension to the holddown screws, tighten the jam screws to lock alignment in place. (NOTE: The milled pads on the front and rear of the holddown should be greased periodically to maintain proper guarding action.)

BACK GAUGE ADJUSTMENT

Slide backgauge rods (62) through the adjustment blocks (66) and brackets (71). Mount the rods in the holes found at the rear of the cutter bar. Move the gauge angle (63) up the rods until it contacts with the lower blade. Observe the pointers attached to the adjustment blocks and adjust the rods in or out until the embossed scales read zero on the pointers. Tighten the set screws (44) to lock rods in place.

To attain a particular setting, loosen the four lock screws (70) and slide the gauge to an approximate position. Fine tune adjustments are accomplished by locking the screws of the two adjustment brackets (71) while keeping those of the blocks (66) loose. The adjustment dial (67) can then be used to position the gauge in or out.

SHARPENING BLADES

Your TENNSMITH shear features "Tri-Action" ground blades. The upper blade has two cutting edges which are ground with a 2° edge relief. The upper blade can be turned over to expose the new cutting edge. It can be sharpened on a surface grinder by grinding both wide sides of the blade. The lower blade has one cutting edge with a 2° edge relief and a 1° face relief. It can be sharpened on a surface grinder by grinding the wide side of the blade having the 1° relief. (See Figure 2). Blade sharpening service is available from the factory.

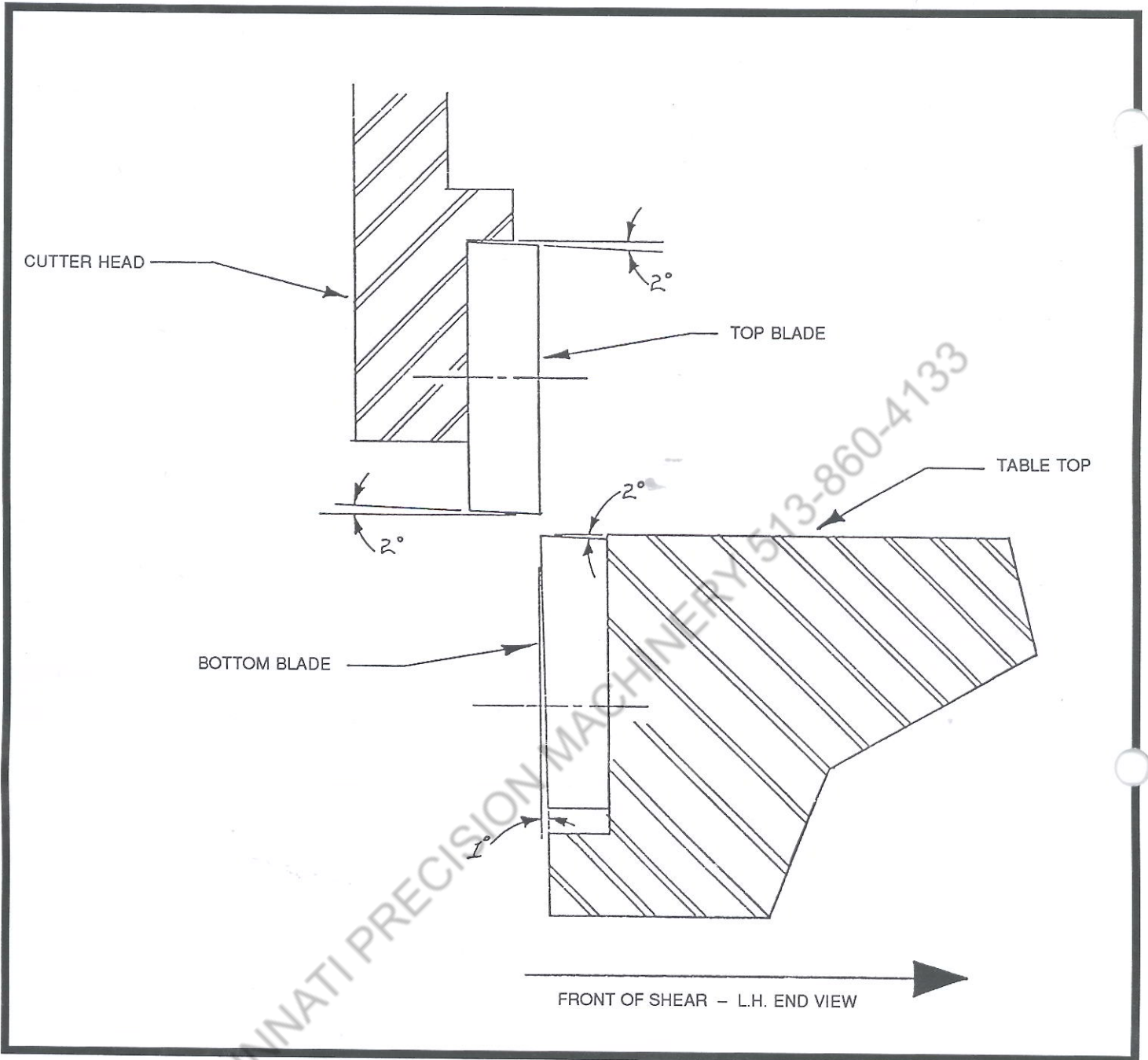

FIGURE 2