

No. 812, 814, 816 Operations Manual

CARE: Occasional oiling of moving parts with machine oil will ease operation and extend the life of the brake. Occasionally check and tighten the lower beam bracket gib screws (see figure 1) at each end of the brake. These screws are accessible when the apron is raised. These should be kept snug to reduce excess front to back play in the lower beam.

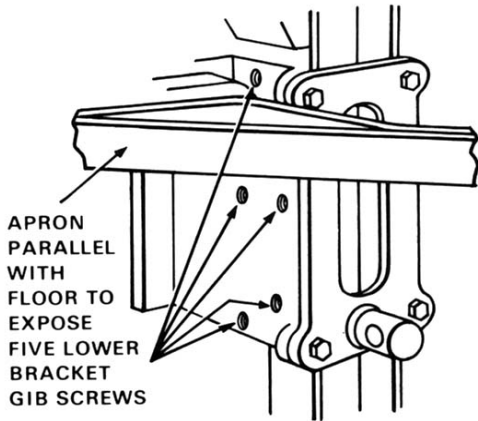

CAUTION: Do not form wire, nails, rods or pipe in these brakes. These brakes will form a 1" flange over the entire length in their rated capacity.

Brakes are reduced in capacity by 2 gauges when:

1. Apron angle iron work support (see figure 2) is removed.
2. Box fingers are used,

Brakes are reduced in capacity by 4 gauges when:

1. Apron angle iron work support and apron filler plate are removed.
2. Brake is used on stainless steel.

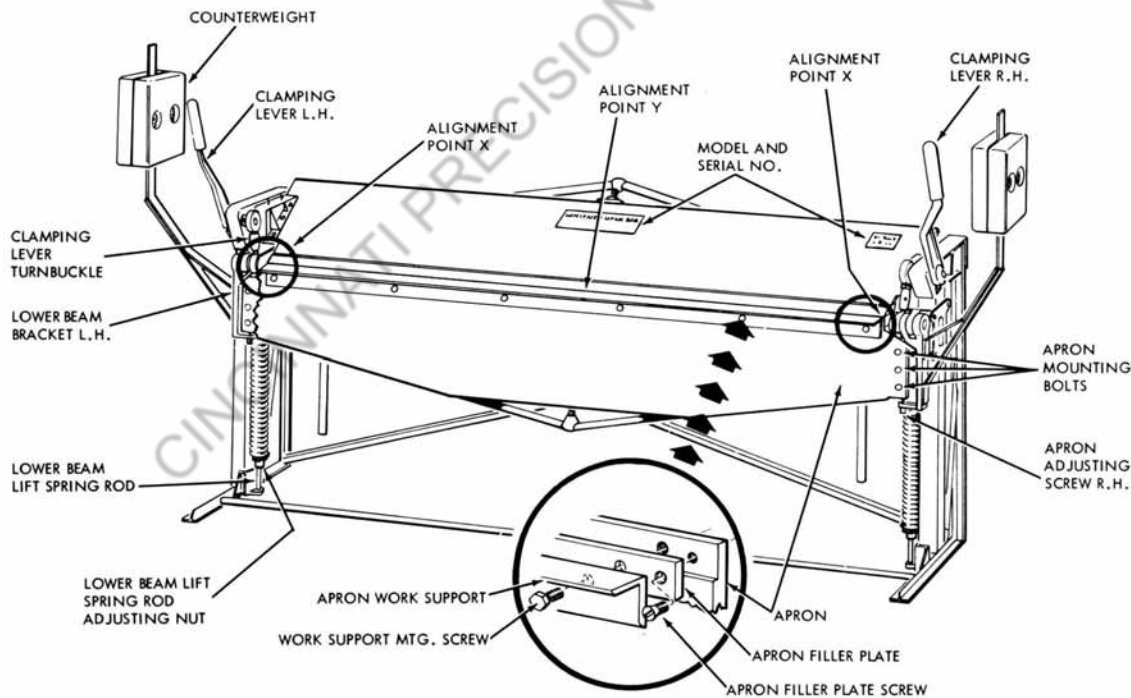

ADJUSTMENTS - BEFORE OPERATION

1. Apron must be flushed with lower beam jaw before beginning operation. To adjust loosen apron mounting bolts slightly and turn apron adjusting screws as necessary. After adjustment, retighten apron mounting bolts. If alignment cannot be achieved, follow major brake alignment procedure following.

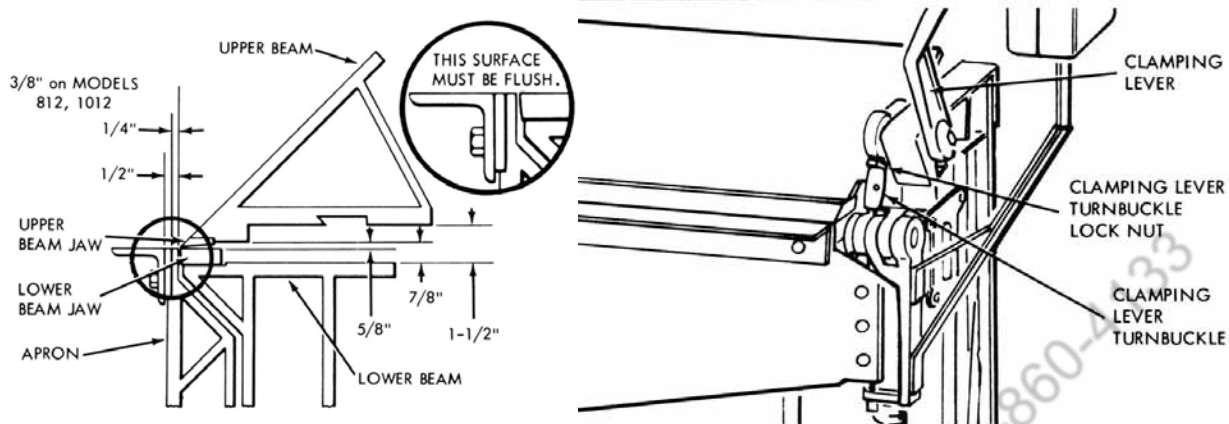

CLAMPING PRESSURE ADJUSTMENT

2. Check gauge of material to be formed to be sure it is within rated capacity of your brake. Place small sample of work piece on Lower Beam Jaw and clamp in position by moving the Clamping Lever forward. Sample should now be held firmly in position. To adjust for more or less clamping pressure, move Clamping Lever to unlocked (up) position, loosen the Clamping Lever Turnbuckle Lock Nut (figure 4) on both ends of brake and adjust the Clamping Lever Turnbuckles as necessary to achieve firm clamping pressure. Retighten the lock-nuts.

THICKNESS OF MATERIAL ADJUSTMENT:

3. Loosen the Upper Beam Slide Clamping Screws (figure 5) and Upper Beam Adjusting Screw Lock Nuts at both ends of brake. Set entire front edge of Upper Beam Jaw back from the Lower Beam Jaw the thickness of the metal to be bent by turning the Upper Beam Adjusting Screws back as necessary. Retighten all screws and nuts.

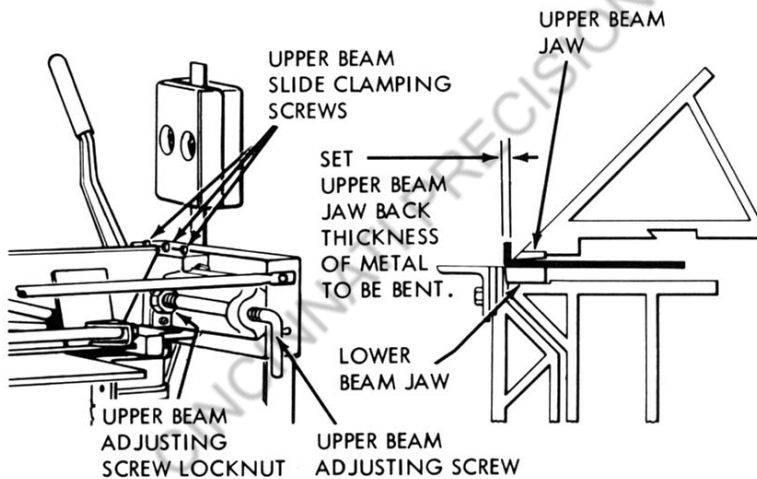

ADJUSTMENTS - FINE ALIGNMENT:

1. A sample work piece, the entire length of the brake, should be clamped in place. Make a test bend by lifting the Apron a full 90°. Release metal from brake jaws and check for straightness.
2. ADJUSTMENTS FOR BOWING: (Refer to figure 7 for location of Truss Nuts).



PROBLEM: Bows up.
SOLUTION: Release tension on Truss Nut (B).



PROBLEM: Bows down.
SOLUTION: Tighten Truss Nut (B). Level the Apron with the Lower Beam Jaw (see figure 3).



PROBLEM: Bows toward operator.
SOLUTION: Release some tension on Truss Nut (D) (depending on your brake).



PROBLEM: Bows away from operator.
SOLUTION: Tighten Truss Nut (D) (depending on your brake).

3. ADJUSTMENT FOR UNEVEN ANGLE OF BEND: If 90° sample bend is true at both ends but less than 90° at center of piece, loosen Apron Mounting Bolts (figure 2) and lower the Apron approximately 1/32" by unscrewing the Apron Adjusting Screws. Retighten the Apron Mounting Bolts and tighten Truss Nut (C, figure 7) until both jaws of brake are flush at brake center (see figure 3).

INCREASING JAW OPENING:

The opening between the brake jaws may be increased to a maximum of 1-5/8". With the Clamping Levers in the unlocked position, turn the Lower Beam Lift Spring Rod Adjusting Nut (figure 2) at each end of brake downward until the desired opening is obtained.

CAUTION: The lower beam lift springs support the weight of the entire lower beam assembly when the brake is unclamped. Always adjust the lower beam spring adjusting nuts with the brake in the unclamped position. If adjusted with the brake in the clamped position the beam, when unclamped, will drop rapidly downward causing the clamping handles to snap backwards.

ENDWISE ADJUSTMENT OF LOWER BEAM:

If the ends of the Upper Beam Jaw and Lower Beam Jaw do not line up at the alignment points (X, figure 2), adjust as follows:

1. Loosen Upper Beam Adjusting Screw Lock Nut (figure 5) at both ends of brake. Turn Upper Beam Adjusting Screws until entire Upper Beam is drawn back about 5" so the Lower Beam Bracket Stud alignment holes (figure 6) are easily accessible.
2. Use a wrench to loosen the Lower Beam Bracket Stud Nut at each end of the brake.
3. Insert a large screwdriver through the alignment hole in the Lower Beam Brackets and adjust the Lower Beam Bracket Studs as necessary. Tightening stud on one end of the brake and loosening it on the other end will shift the Lower Beam to the right or left permitting alignment of the Upper and Lower Beam ends.

CAUTION: Make sure the Lower Beam Bracket Stud does not bear too tightly against the inside leg. This will cause the lower beam to bind and make the brake inoperative. Leave approximately 1/32" clearance between the lower beam bracket stud and the inside leg on each side of the brake.

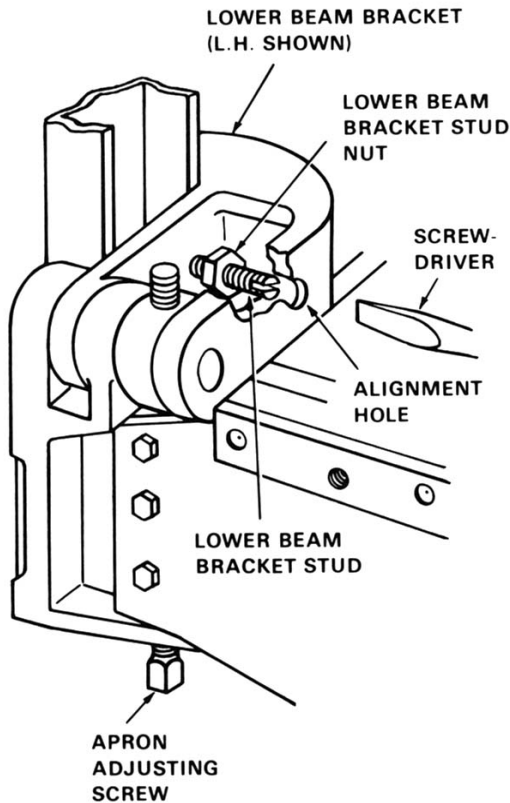

MAJOR BRAKE ALIGNMENT:

Follow the procedure listed below if brake is badly out of alignment. (if your brake does not have all the Truss Nuts referred to in these instructions, disregard those steps.) A 30" length of one inch pipe will help attain necessary leverage when applied to the end of the wrench supplied with the brake.

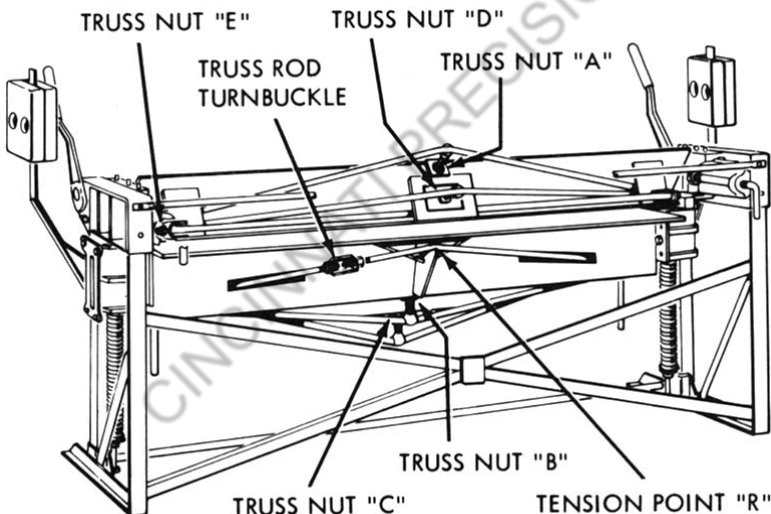

1. Loosen all Truss Nuts (A, B, C, D, E, figure 7) and Truss Rod Turnbuckle until all tension is released.
2. Tighten the Truss Rod Turnbuckle until the rods are snug at tension point (R). Tighten an additional 1/4 turn.
3. Tighten Truss Nut (B) until snug, -Tighten an additional three complete turns.
4. Check Apron at the alignment points (X, figure 2) to see if it is flush with top of Lower Beam Jaw (see inset, figure 2.) Up and down movement of the Apron is controlled by turning the Apron Adjusting Screw (figure 2) at each end of the Apron.
5. Tighten Truss Nut (C, figure 7) until Apron is flush with Lower Beam Jaw at alignment point (Y, figure 2).
6. Tighten Truss Nut (E, figure 7) as tight as possible.
7. Tighten Truss Nut (A) until the Upper Beam Jaw is straight and parallel in relation to the Lower Beam Jaw.

8. Tighten Truss Nut (D) until the center of the Upper Beam Jaw bows forward slightly.

STRAIGHT BENDING:

Set Upper Beam Jaw back to thickness of metal to be bent. (See figure 5). Bends up to 135° may be achieved by raising the Apron until the desired angle of bend is obtained. (See figure 8).

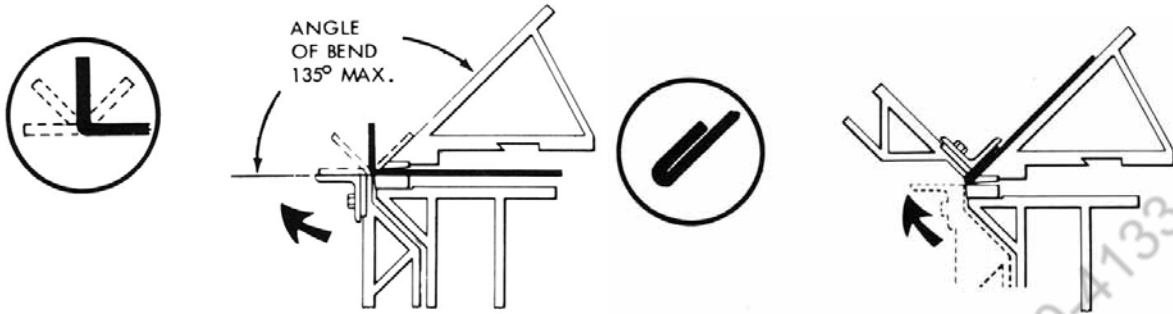

FLATTENED SEAM BENDING:

Bend metal to full 135° angle as explained above (figure 8). Remove metal from between the jaws and reposition it against the Upper Beam as shown in figure 9. Lift Apron to flatten seam.

JOINTING:

Bend metal piece to full 135° angle. Remove metal from between the jaws and reposition it against the Upper Beam in same manner as explained above. Lift Apron to complete bend. Do not flatten seam; but, allow for thickness of metal piece to be jointed.

The Roper Whitney No. 9 Button Punch Tool may be used to lock the two pieces together securely.

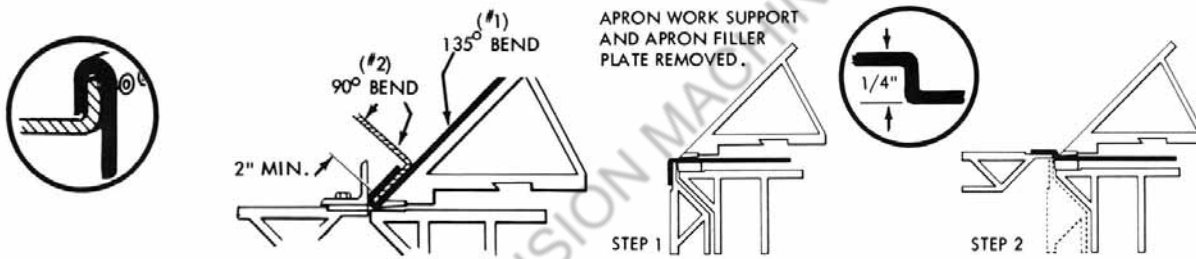

MINIMUM REVERSE BENDING:

Remove Apron Angle Iron Work Support and Apron Filler Plate (inset, figure 2). This permits 1/4" reverse bends to be made on all brakes except Model Nos. 812, 1012, and 1214 will make a reverse bend of 3/8".

NOTE: When the Apron Angle Iron Work Support and Apron Filler Plate is removed, the brake capacity is reduced by 4 gauges.

To accomplish a minimum reverse bend, a metal lip is first bent to a 90° angle. Metal piece is removed and repositioned between the jaws as shown in Step 1 (figure 11). Raise Apron 90° to complete bend, Step 2 (figure 10).

REPEAT BENDS:

Repeat bends can be made easily by using the apron gauge illustrated below. Make the first bend to the desired degree and clamp apron gauge bar stop collar using set screw in position. Apron will contact stop and insure accurate repeatability of bend.

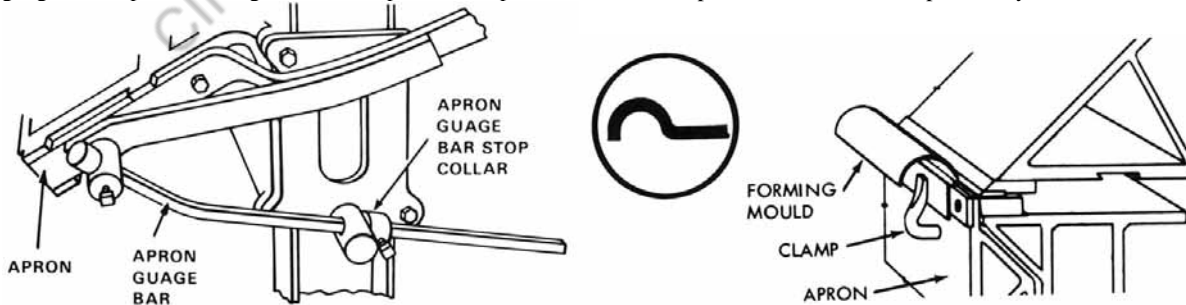

TINNER'S MOULDING FORMS:

One set of five standard sizes of Tinner's Mould; 5/8", 1", 1-5/8", 2-1/2", and 3" is available for all sizes of Combination Bending Brakes. Remove the Apron Angle Iron Work Support and position the forming mold on the lip of the Apron (see figure 13). Use a hammer to tap the moulding form clamps through the holes in the Apron of the brake. Metal piece part is wiped over the moulding form manually to obtain desired radius.

RADIUS FORMING:

Radius Former Bars are available for all sizes of Combination Bending Brakes. These bars are available in sizes from 3/32" to 1" in increments of 1/32". Sizes 1", 1-1/2", 2", and 2-1/2" are available. The number of Radius Holder Fingers required depends upon the length of the brake; 3 Holder Fingers are required for a 4 foot brake, 4 are required for a 6 foot brake, 5 are required for an 8 foot brake, and 6 for a 10 foot brake. Holder Fingers are all alike for all brake lengths. Shorter Radius Former Bars may be installed on longer brakes if desired.

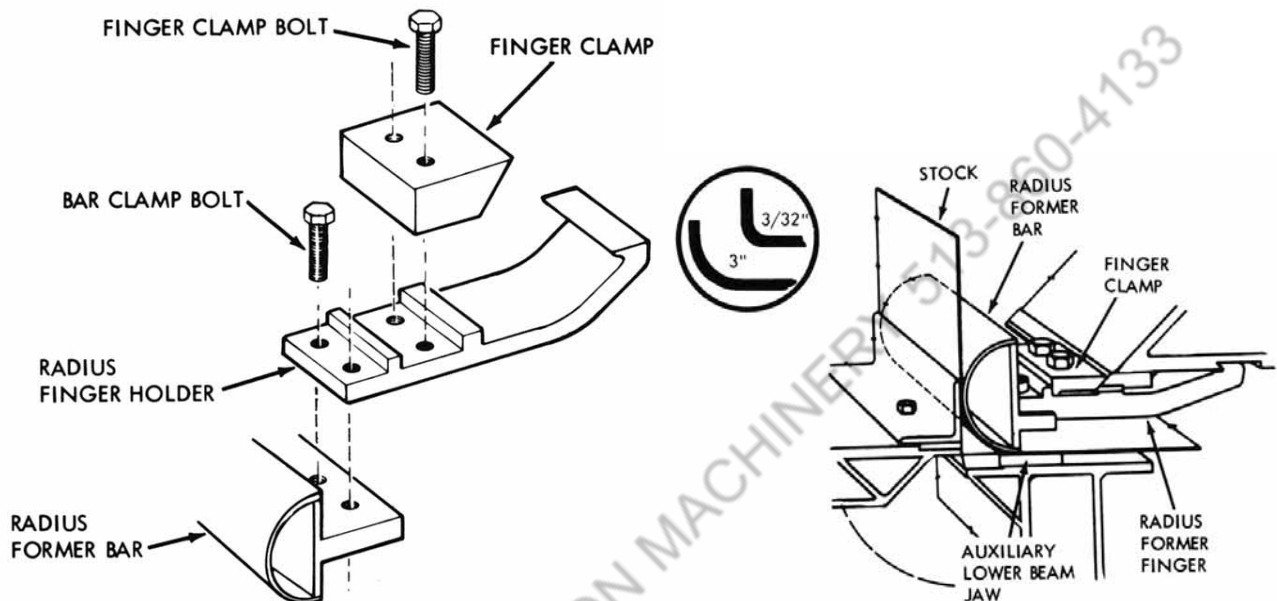

INSTALLING RADIUS FORMER BARS:

1. Assemble the necessary number of Radius Finger Holders to the Radius Forming Bar as shown in figure, 14.
2. Increase the distance between the brake jaws by turning the Lower Beam Lift Spring Rod Adjusting Nut (figure 2) at each end of brake downward as far as it will go.

CAUTION: The lower beam lift springs support the weight of the entire lower beam assembly when the brake is unclamped. Always adjust the lower beam spring adjusting nuts with the brake in the undamped position. If adjusted with the brake in the clamped position the beam, when unclamped, will drop rapidly downward causing the clamping handles to snap backwards.

3. When using a 1-1/2" or larger Radius Forming Bar, an Auxiliary Lower Beam Jaw is required and should be inserted in position behind the lower Beam Jaw (figure 15).
4. Loosen the Upper Beam Slide Clamping Screws (figure 5) and Upper Beam Adjusting Screw Lock Nuts at both ends of brake. Move the entire Upper Beam back far enough to accommodate the assembled Radius Former Finger and Bar (figure 15).
5. Loosen Finger Clamp Bolts and hook Holder Finger into dove tail in Upper Beam. Position lip of Clamp over Upper Beam Jaw and tighten Finger Clamp Bolts securely.
6. Move Upper Beam back or forward as necessary until front edge of Radius Former Bar is back from the Lower Beam Jaw the thickness of the metal to be bent. (see figure 15). Tighten all Upper Beam Slide Clamping Screws and Adjusting Screw Lock Nuts.
7. With Clamping Lever in unlocked (up) position, adjust Clamping Lever Turnbuckles (figure 4) and Lower Beam Lift Spring Rod Adjusting Nuts as necessary to obtain desired clamping pressure. Pressure should be firm enough so metal will not slip when clamped.

CAUTION: The lower beam lift springs support the weight of the entire lower beam assembly when, the brake is unclamped. Always adjust the lower beam spring adjusting nuts with the brake in the unclamped position. If adjusted with the brake in the clamped position the beam, when unclamped, will drop rapidly downward causing the clamping handles to snap backwards.

BOX AND PAN BENDING:

Box Fingers are available for all Combination Bending Brakes in widths from 1" through 6" in increments of 1/2", and an 8" width. They are made in 6" and 8" depths.

The size and number of Box Fingers required can easily be determined as follows:

1. Largest dimension of box or pan determines the quantity of Box Fingers required.
2. Depth of box or pan determines the Box Finger depth.

Example: To make a box 10" wide x 15" long x 7" deep; use 8" deep Box Fingers in following combinations:

- 2 - 4" wide Box Fingers (or 1 - 8" wide)
- 1 - 2" wide Box Finger
- 10" bend can now be made.
- Add 1 - 5" wide Box Finger
- 15" bend can now be made.

Any combination of Box Fingers that add up to the required total may be used.

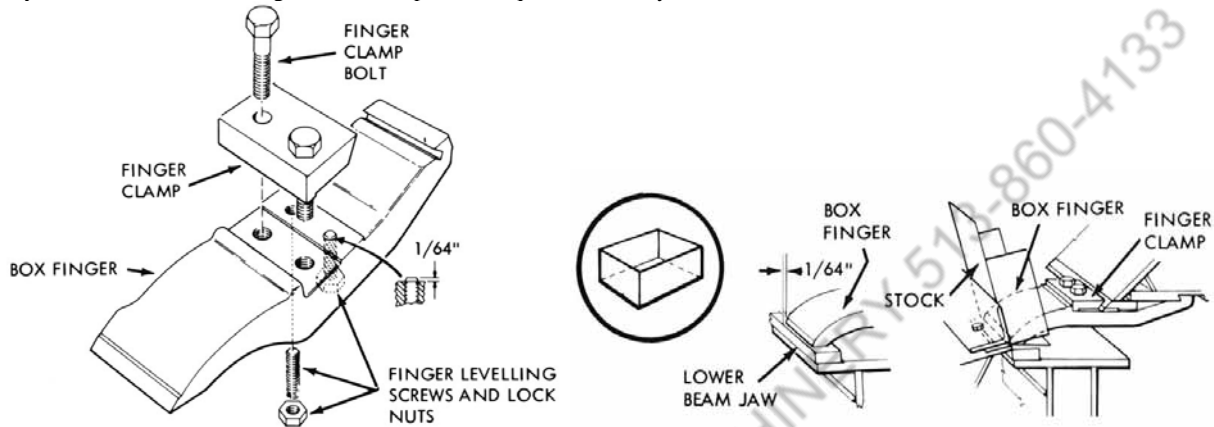

INSTALLING BOX FINGERS

With Clamping Lever in unlocked position, proceed as follows:

1. Turn Lower Beam Lift Spring Rod Adjusting Nuts (figure 2) down to bottom at both ends of brake.
2. Loosen all Upper Beam Slide Screws and Upper Beam Adjusting Screw Lock Nuts. Move Upper Beam to the rear by turning Upper Beam Adjusting Screws back to accommodate either 6" or 8" depth fingers.
3. Open Clamping Lever Turnbuckles (figure 4). A rod may be inserted through holes in Turnbuckles for ease in turning.
4. Loosen Finger Clamp Bolts (figure 16) and hook finger into dove tail of Upper Beam. Position lip of Clamp over Upper Beam Jaw and tighten Finger Clamp Bolts securely.
5. Move Upper Beam back or forward as needed so that finger bending nose is 1/64" back from front edge of Lower Beam Jaw (figure 17). Use Upper Beam Adjusting Screws (figure 5).
6. Tighten Upper Beam Slide Clamping Screws and Upper Beam Adjusting Screw Lock Nuts.
7. Adjust Clamping Lever Turnbuckles and Lower Beam Lift

Spring Rod Adjusting Nuts to attain proper clamping pressure. Pressure should be firm enough so metal will not slip when clamped.

NOTE: When using partial quantities of fingers, always mount fingers in the middle of brake to equalize strain. When bending with fingers, capacity is 2 gauges lighter. A 14 gauge brake with Box Fingers installed will handle 16 gauge or lighter material only.

FINGER ALIGNMENT:

If bottom of Box Fingers are not flush, align as follows:

1. Choose a 4" to 6" width finger and set the Finger Leveling screws (figure 16) until end of each screw protrudes 1/64" above mounting surface of the finger. Lock the screws in this position by securely tightening Finger Leveling Lock Nuts.
2. This finger is now the master finger and should be mounted in the center of the Upper Beam. Be sure that finger is square when tightening Finger Clamp Bolts. All other fingers are now adjusted to this master finger.
3. Set Finger Leveling Screws of remaining Box Fingers approximately the same as master finger. Mount finger on brake on right side of master finger. Do not allow side of finger to touch side of master finger (allow about 1/32"). Tighten Finger Clamp Bolts and check to see if bottom of finger is flush with bottom of master finger. Adjust up or down as required by turning Finger Leveling Screws in or out. This can be done from rear of brake while finger is clamped in place. Finger Clamp Bolts may require slight loosening at times while Finger Leveling Screws are turned. Be sure Finger Clamp Bolts are securely tightened before checking new adjustment.
4. When adjustment is correct, remove finger and remount on left side of master finger and check again. If bottom edges are not level, correct as in step 3. Tighten Finger Leveling Lock Nuts securely.

5. Remove this finger and set aside. Then proceed to adjust all other fingers in the same manner.
6. When all fingers have been adjusted to master finger, they may be assembled on nose of brake in any combination and they will all align with each other.

LOWER BEAM ASSEMBLY

Item No.	Part Name	MODEL NO. 812		MODEL NO. 814		MODEL NO. 816	
		No. Req.	Part No.	No. Req.	Part No.	No. Req.	Part No.
72	Apron Gauge Bar	1	416-43	1	416-43	1	416-43
73	Apron Gauge Bar Stop Collar	1	416-54	1	416-54	1	416-54
74	Apron Gauge Bar Stop Collar Set Screw 3/8-16 x 3/4 Square Head	1	WS 628	1	WS 628	1	WS 628
75	Apron Stop Swivel Pin	1	812-24	1	416-40	1	41 6-40
76	Apron Stop Swivel Pin Cotter Key 3/32 x 1 1/4	1	WS 1528	1	WS 1528	1	WS 1528

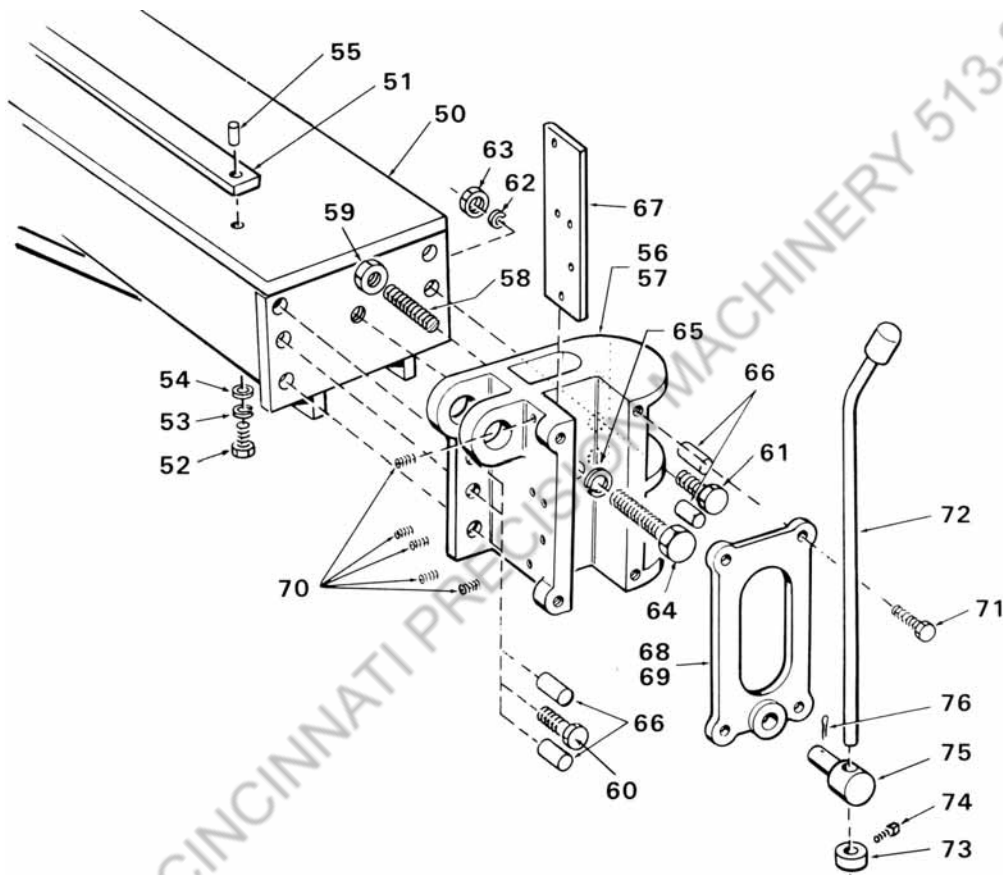

UPPER BEAM ASSEMBLY

Item No.	Part Name	Model No. 812		Model No. 814		Model No. 816	
		No. Req.	Part No.	No. Req.	Part No.	No. Req.	Part No.
1A	Upper Beam Complete (Shipped Complete Only) Consists of:	1	812-1M	1	814-1 M	1	816-1 M
1	Upper beam	1	Available only as Assembly 812-1M above	1	Available only as assembly 814-1M above	1	Available only as Assembly 8 6-1M above
2	Upper Beam Jaw	1	816-5	1	816-5	1	816-5
3	Upper Beam Jaw Mounting Screws 5/16-18 x 5/8 Flat Head Socket Cap Screws	17	WS 2528	17	WS 2528	17	WS 2528
4	Upper Beam Slide Casting - RH	1	812-6	1	412-6	1	412-6
5	Upper Beam Slide Casting - LH	1	812-7	1	412-7	1	412-7
6	Upper Beam Slide Gibs	2	812-23	2	412-15	2	412-15
7	Upper Beam Slide Set Screws 1/2-13 x 1-3/4 Square Head	8	WS 657	6	WS 657	6	WS 657
8	Upper Beam Bottom Plate Screw 1/2-13 x 1-3/4 Hex Head	8	WS 66	4	WS 66	4	WS 66
9	Upper Beam Bottom Plate Screw Washer 1/2 Lock	8	WS 1731	4	WS 1731	4	WS 1731
10	Bottom Adjusting Screw	10	WS 875 1/2-13 x 1 Socket Set	6	WS 848 3/8-16 x 3/4 Socket Set	6	WS 848 3/8-16 x 3/4 Socket Set
11	Bottom Adjusting Screw Lock Screw	10	WS 1925 1/2-13 x 1/4 Socket Set	6	WS 1926 3/8-16 x 3/16 Socket Set	6	WS 1926 3/8-16 x 3/16 Socket Set
12	Upper Beam to Slide Mounting Screw 5/8-11 x 2-1/4 Hex Head	8	WS 95	6	WS 95	6	WS 95
13	Upper Beam to Slide Mounting Screw Lock Washers 5/8 Lock	8	WS 1733	6	WS 1733	6	WS 1733
14	Upper Beam to Slide Mounting Screw Nuts 5/8-11 Full	8	WS 1358	6	WS 1358	6	WS 1358
15	Upper Beam Adjusting Screw Plates	6	416-29	6	416-29	6	416-29
16	Upper Beam Adjusting Screw Plate Mounting Screws 3/8-16 x 3/4 Hex Head	4	WS 31	4	WS 31	4	WS 31
17	Upper Beam Adjusting Screw	2	416-35	2	416-35	2	416-35
18	Upper Beam Adjusting Screw Nut	2	416-67	2	416-67	2	416-67

LOWER BEAM ASSEMBLY

Item No.	Part Name	MODEL NO. 812		MODEL NO. 814		MODEL NO. 816	
		No. Req.	Part No.	No. Req.	Part No.	No. Req.	Part No.
50	Lower Beam	1	812-2M	1	814-2M	1	816-2M
51	Lower Beam Jaw	1	816-8	1	816-8	1	816-8
52	Lower Beam Jaw Mounting Screw	17	WS 153 5/16-18 x 1-1/8 Hex Head	9	WS 17 5/16-18 x 7/8 Hex Head	17	WS 153 5/16-18 x 1-1/8 Hex Head
53	Lower Beam Jaw Mounting Screw Lock Washer 5/16 Lock	17	WS 1728	9	WS 1728	17	WS 1728
54	Lower Beam Jaw Mounting Screw Flat Washer 5/16 Flat	17	WS 1703	9	WS 1703	17	WS 1703
55	Lower Beam Jaw Dowel Pin 1/4 x 1-1/8	8	WS 1593	4	WS 1593	8	WS 1593
56	Lower Beam Bracket RH Complete Includes: (Shipped Complete Only)	1	812-4	1	412-2-9	1	412-29
58	Lower Beam Bracket Stud	1	416-30	1	416-30	1	416-30
59	Lower Beam Bracket Stud Nut 5/8-11 Hex Jam Nut	1	WS 1337	1	WS 1337	1	WS 1337
70	Lower Beam Bracket Gib Screws 3/8-16 x 3/4 Headless Set Screw	5	WS 728	5	WS 728	5	WS 728
57	Lower Beam Bracket LH Complete Includes: (Shipped Complete Only)	1	812-5	1	412-30	1	412-30
58	Lower Beam Bracket Stud	1	416-30	1	416-30	1	416-30
59	Lower Beam Bracket Stud Nut 5/8-11 Hex Jam Nut	1	WS 1337	1	WS 1337	1	WS 1337
70	Lower Beam Bracket Gib Screws 3/8-16 x 3/4 Headless Set Screw	5	WS 728	5	WS 728	5	WS 728
60	Lower Beam Bracket Mounting Screw	2	416-88	2	416-88	2	416-88
61	Lower Beam Bracket Mounting Screw	2	WS 97 5/8-11 x 2-3/4 Hex Head	2	WS 96 5/8-11 x 2-1/2 Hex Head	2	WS 96 5/8-11 x 2-1/2 Hex Head
62	Lower Beam Bracket Mounting Screw Lock Washer 5/8 Lock	2	WS 1733	2	WS 1733	2	WS 1733
63	Lower Beam Bracket Mounting Screw Nut 5/8-11 Hex Full Nut	2	WS 1358	2	WS 1358	2	WS 1358
64	Lower Beam Bracket Mounting Screw 5/8-11 x 4-1/2 Hex Head	2	WS 103	2	WS 103	2	WS 103
65	Lower Beam Bracket Lock Washer 5/8 Lock	2	WS 1733	2	WS 1733	2	WS 1733
66	Lower Beam Locating Pins	8	412-31	8	412-31	8	412-31
67	Lower Beam Bracket Gibs	2	812-16	2	412-32	2	412-32
68	Lower Beam Bracket Plate RH	1	812-19	1	412-28	1	412-28
69	Lower Beam Bracket Plate LH	1	812-22	1	412-25	1	412-25
71	Lower Beam Bracket Plate Mounting Screws	8	WS 64 1/2-13 x 1-1/4 Hex Head	8	WS 63 1/2-13 x 1 Hex Head	8	WS 63 1/2-13 x 1 Hex Head

APRON ASSEMBLY

Item No.	Part Name	MODEL NO. 812		MODEL NO. 814		MODEL NO. 816	
		No. Req.	Part No.	No. Req.	Part No.	No. Req.	Part No.
100A	Apron Complete (Shipped Complete Only) Consists of:	1	812-3M	1	814-3M	1	816-3M
100	Apron	1	Available only as assembly 812-3M above	1	Available only as Assembly 814-3M above	1	Available only as Assembly 816-3M above
101	Apron Jaw	1	816-7	1	816-7	1	816-7
102	Apron Jaw Screws 5/16-18 x 3/8 Socket Flat Head Screw	17	WS 2526	17	WS 2526	17	WS 2526
103	Apron Jaw Dowel Pins 1/4 Dia. x 7/16	6	WS 1682	6	WS 1682	6	WS 1682
104	Apron Work Support	1	816-12	1	816-12	1	816-12
105	Apron Work Support Screw 5/8-11 x 3/4 Hex Head	6	WS 145	6	WS 145	6	WS 145
106A	Apron Hinge RH Complete (Shipped Complete Only) Consists of:	1	812-35	1	412-35	1	412-35
106	Apron Hinge RH	1	Available only as Assembly 812-35 above	1	Available only as Assembly 412-35 above	1	Available only as Assembly 412-35 above
108	Apron Adjusting Screws	1	WS 679 5/8-11 x 1-3/4 Sq. Head	1	WS 657 1/2-13 x 1-3/4 Sq. Head	1	WS 657 1/2-13 x 1-3/4 Sq. Head
109	Apron Hinge Bearings Torrington	2	416-98 BH 2824	2	416-97 BH 2216	2	416-97 BH 2216
107A	Apron Hinge LH Complete (Shipped Complete Only) Consists of:	1	812-36	1	412-36	1	412-36
107	Apron Hinge LH	1	Available only as Assembly 812-36 above	1	Available only as Assembly 412-36 above	1	Available only as assembly 412-36 above
108	Apron Adjusting Screws	1	WS 679 5/8-11 x 1-3/4 Sq. Head	1	WS 657 1/2-13 x 1-3/4 Sq. Head	1	WS 657 1/2-13 x 1-3/4 Sq. Head
109	Apron Hinge Bearings Torrington	2	416-98 BH 2824	2	416-97 BH 2216	2	416-97 BH 2216
110	Apron Hinge Mounting Bolts	8	WS 94 5/8-11 x 2 Hex Hd.	6	WS 94 5/8-11 x 2 Hex Hd.	6	WS 94 5/8-11 x 2 Hex Hd.
111	Apron Hinge Mounting Bolt Washers 5/8 Lock	8	WS 1733	6	WS 1733	6	WS 1733
112	Apron Hinge Mounting Bolt Nuts 5/8-11 Hex Full	8	WS 1358	6	WS 1358	6	WS 1358
113	Apron Hinge Shims	As Req.	812-27	As Req.	412-27	As Req.	412-27
114	Apron Bumper Spring Screw 3/8-16 x 2 Hex Hd.	2	WS 37	2	WS 37	2	WS 37
115	Apron Bumper Spring	2	416-41	2	416-41	2	416-41
		2	127-75	-	-	-	-
116	Apron Bumper Spring Screw Nuts 3/8-16 Hex Jam	4	WS 1333	4	WS 1333	4	WS 1333
117	Apron Hinge Pin	2	812-34	2	416-31	2	416-31
118	Apron Hinge Pin Retaining Rings	4	WS 1973 1-3/4 Tru Arc Rings	4	WS 1974 1-3/8 Tru Arc Rings	4	WS 1974 1-3/8 Tru Arc Rings
119	Lower Eyebolt	2	812-17	2	416-25	2	416-25
120	Turnbuckle	2	812-18	2	416-26	2	416-26
121	Upper Eyebolt	2	812-33	2	416-78	2	416-78
122	Turnbuckle Lock Nut	2	812-45	2	WS 1340 1/8 Hex Jam	2	WS 1340 1/8 Hex Jam

APRON ASSEMBLY

Item No.	Part Name	Model No. 812		Model No. 814		Model No. 816	
		No. Req.	Part No.	No. Req.	Part No.	No. Req.	Part No.
123-	Counterweight Arm RH	1	812 1 4	1	412-24	1	412-24
124-	Counterweight Arm LH	1	812-13	1	412-41	1	412-41
125-	Counterweights	4	816-6	2	616-22	2	616-22
126-	Counterweight Bolts	4	WS 2188 5/8-11 x 5-1/2 Carriage Bolts	2	816-6	2	816-6
127-	Counterweight Washers	4	WS 1708 5/8 Flat	4	WS 2109 1/2-13 x 4-1/2 Carriage Bolts	4	WS 2109 1/2-13 x 4-1/2 Carriage Bolts
128-	Counterweight Nuts	4	WS 1388 5/8-11 Sq. Nut	4	WS 1706 1/2 Flat	4	WS 1706 1/2 Flat
129-	Counterweight Arm Mounting Screw 1/2-13 x 1-1/4 Hex Head	4	WS 64	4	WS 1386 1/2-13 Sq. Nut	4	WS 1386 1/2-13 Sq. Nut
130-	Counterweight Arm Mounting Screw Washer 1/2 Lock	4	WS 1731	4	WS 64	4	WS 64
131-	Apron Stop Swivel Pin	1	416-38	1	WS 1731	4	WS 1731
132-	Apron Stop Swivel Pin Cotter Key 3/32 x 1-1/4	1	WS 1528	1	416-38	1	416-38
133-	Apron Stop Swivel Set Screw 3/8-16 x 5/8 Square Head	1	WS 627	1	WS 1528	1	WS 1528
					WS 627	1	WS 627

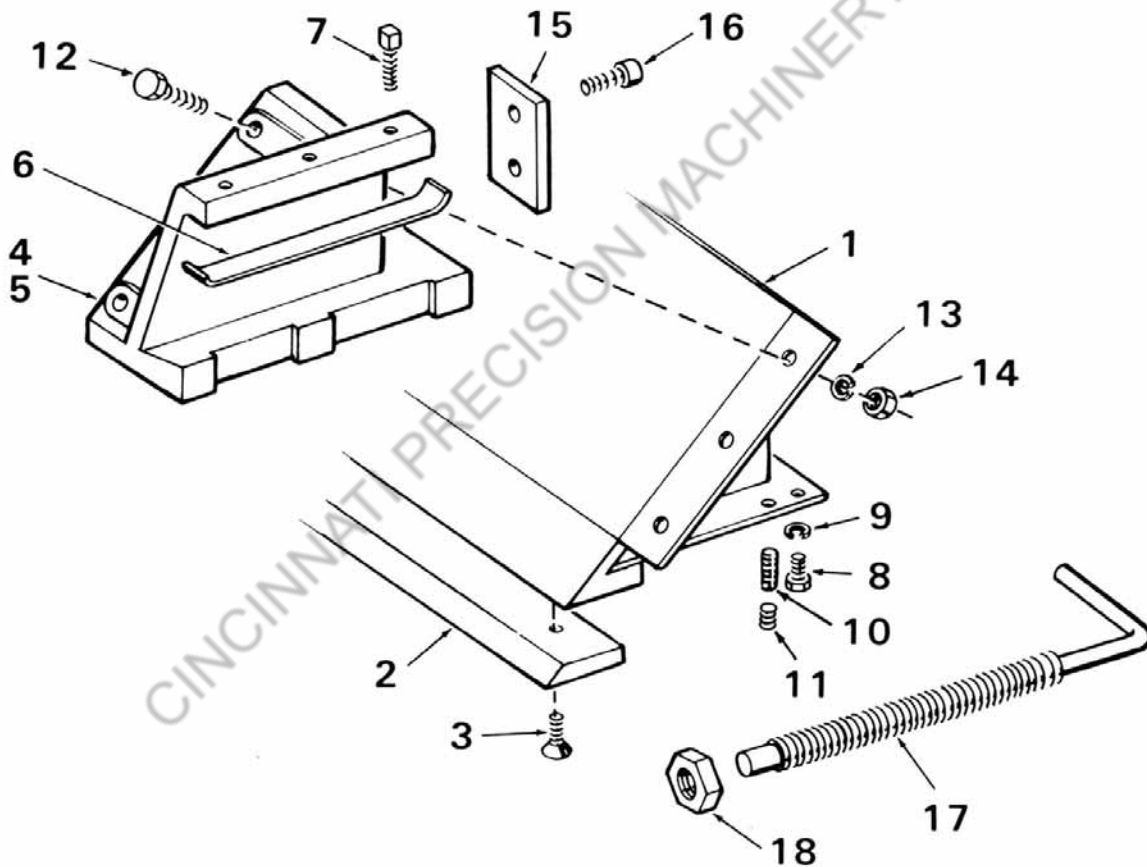

HEAD AND LEG ASSEMBLY

Item No.	Part Name	MODEL NO. 812		MODEL NO. 814		MODEL NO. 816	
		No. Req.	Part No.	No. Req.	Part No.	No. Req.	Part No.
150A	Head Casting RH Complete (Shipped Complete Only) Consists of:	1	812-8	1	412-33	1	412-33
150	Head Casting RH	1	Available only as Assembly 812-8 above	1	Available I only as Assembly 412-33 above	1	Available only as Assembly 412-33 above
157	Brake Crank Bearings Torrington	2	812-75 BH 3324	2	416-98 BH 2824	2	41 6-98 BH 2824
151A	Head Casting LH Complete (Shipped Complete Only) Consists of:	1	812-9	1	412 -34	1	412-34
151	Head Casting LH	1	Available only as Assembly 812-9 above	1	Available only as Assembly 412-34 above	1	Available only as Assembly 412-34 above
157	Brake Crank Bearing Torrington	2	812-75 BH 3324	2	416-98 BH 2824	2	416-98 BH 2824
152	Clamping Lever RH	1	416-16	1	416-1 6	1	41 6-1 6
153	Clamping Lever LH	1	416-17	1	416-1 7	1	41 6-1 7
154	Clamp Lever Washer	2	416-96	2	416-96	2	416-96
155	Clamp Lever Washer Mounting Screw 3/8-16 x 3/4 Hex Head	2	WS 31	2	WS 31	2	WS 31
156	Clamp Lever Washer Mounting Screw Lock Washer 3/8 Lock	2	WS 1729	2	WS 1729	2	WS 1729
158	Brake Crank	2	812-32	2	416-77	2	41 6-7 7
159	Crank and Clamping Lever Key #E Woodruff	2	WS 1951	2	WS 1951	2	WS 1951
160	Roller Bearings Torrington	50	812-31 GAR 32914	50	416-39 CH 350	50	416-39 CH 350
161	Upper Eyebolt Washer	2	416-80	2	416-80	2	41 6-80
162	Washer Mounting Screw 3/8-16 x 3/4 Hex Head	2	WS 31	2	WS 31	2	WS 31
163	Washer Mounting Washer 3 / 8 Lock	2	WS 1729	2	WS 1729	2	WS 1729
164	Leg Bracket Castings	2	812-12	2	41 2-12	2	412-12
165	Leg Bracket Screw	4	WS 102 5/8-11 x 4 Hex Head	4	WS 100 5/8-11 x 3-1/2 Hex Head	4	WS 100 5/8-11 x 3-1/2 Hex Head
166	Leg Bracket Screw Lock Washer 5/8 Lock	4	WS 1733	4	WS 1733	4	WS 1733
167	Leg Bracket Screw Nut 5/8-11 Hex Full	4	WS 1358	4	WS 1358	4	WS 1358
168	Leg Bracket Screw 5/8-11 x 1-3/4 Hex Head	4	WS 93	4	WS 93	4	WS 93
169	Leg Bracket Screw Lock Washer 5/8 Lock	4	WS 1733	4	WS 1733	4	WS 1733
170	Lower Beam Lift Springs	4	812-39	2	816-1 5	2	816-15
171	Lower Beam Lift Spring Rods	4	416-28	2	416-28	2	416-28
172	Lower Beam Lift Spring Rod Adjusting Nuts	4	416-36	2	416-36	2	416-36
173	Tee Iron Leg RH	1	412-21	1	412-21	1	412-21
174	Tee Iron Leg LH	1	412-22	1	412-22	1	412-22
175	Angle Iron Spreader Bar	-	-	1	816-4	1	816-4
175A	Rear Cross Brace	1	812-40	-	-	-	-
176	Angle iron Spreader Bar or, Rear Cross Brace Mounting Screw 1/2-13 x 1 -1/2 Hex Head	4	WS 65	2	WS 65	2	WS 65
177	Angle Iron Spreader Bar or Rear Cross Brace Bevel washer 1/2 Malleable	4	WS 1749	2	WS 1749	2	WS 1749

HEAD AND LEG ASSEMBLY

Item No.	Part Name	MODEL NO. 812		MODEL NO. 814		MODEL NO. 816	
		No. Req.	Part No.	No. Req.	Part No.	No. Req.	Part No.
178	Angle Iron Spreader Bar or Rear Cross Brace Lock Washer 1/2 Lock	4	WS 1731	2	WS 1731	2	WS 1731
179	Angle Iron Spreader Bar or Rear Cross Brace Mounting Nut 1/2 -1 3 Hex Jam	4	WS 1335	2	WS 1335	2	WS 1335
180	Tie Rod	1	816-11	1	816-11	1	816-11
181	Tie Rod Mounting Screw 1/2 -13 x 3/4 Hex Head	2	WS 61	2	WS 61	2	WS 61
182	Tie Rod Mounting Screw Lock Washer 1/2 Lock	2	WS 1731	2	WS 1731	2	WS 1731
183	Back Spreader Bar	1	816-17	1	B16-17	1	816-17
184	Head Screw to T Iron	2	WS 96 5/8-11 x 1-1/2 Hex Head	2	WS 94 5/8-11 x 2 Hex Head	2	WS 94 5/8-11 x 2 Hex Head
185	Head Screw to T Iron 5/8-11 x 2-1/4 Hex Head	2	WS 95	2	WS 95	2	WS 95
186	Head Screw to T Iron Lock Washer 5/8 Lock	4	WS 1733	4	WS 1733	4	WS 1733
187	Head Screw to T Iron Nuts 5/8-11 Hex Full	4	WS 1358	4	WS 1358	4	WS 1358
188	Leg Brace	2	41 6-55-1	2	41 6-55-1	2	41 6-55-1
189	Leg Brace Screw 1/2 -13 x 1-1/2 Hex Head Screw	2	WS 65	2	WS 65	2	WS 65
190	Leg Brace Screw Washer 1/2 Lock	2	WS 1 731	2	WS 1731	2	WS 1731
191	Leg Brace Screw Nut 1/2-13 Hex Jam	2	WS 1335	2	WS 1335	2	WS 1335
192-	I Beam Leg	2	412-26	2	412-26	2	412-26
193	Head Screw to I Beam 5/8-11 x 1-3/4 Hex Head	4	WS 93	4	WS 93	4	WS 93
194	Head Screw to I Beam Washer 5/8 Lock	4	WS 1733	4	WS 1733	4	WS 1733
195	Wrench (Not Shown)	1	416-70	1	416-70	1	416-70
196	Wrench (Not Shown)	1	812-70	NOT USED ON 814 AND 816 BRAKES			
197	Lift Spring Rod Bracket R.H.	1	812-26				
198	Lift Spring Rod Bracket LH	1	812-28				
199	Brake Head Washer	2	812-46				

