

Operator's Manual TDC-V

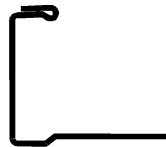

CINCINNATI PRECISION MACHINERY 513-860-4133



LOCKFORMER

A PRODUCT OF

FORMTEK
More Productive Metalforming Solutions

VER. INT. TDC V-02
03-2005

TABLE OF CONTENTS

Safety Guidelines	2
Warranty	3
Safety Sign-Off Sheet	4-5
Tooling	6
Installation	6
Operation of TDC Joint Profile Rollset (Shown Mounted on the Left Outboard Shafts)	7
<i>Sliding Stock Guide (Small Parts Feeder)</i>	8
<i>Sheet Hold Down Roll Assembly</i>	9
<i>Stud Nut Adjustment</i>	9
<i>Shims Between Machine Plates</i>	11
<i>Idler Rolls</i>	11-12
<i>Exit Straightener</i>	13
<i>Entrance Gauge Bar Settings</i>	14
Operation of Optional TDC Clip Rolls Mounted on the Outboard Shafts	11-13
<i>Entrance Gauge Bar Settings</i>	11
<i>Stud Nut Adjustment</i>	12
<i>Shims Between Machine Plates</i>	12
<i>Rollshims and Spacers</i>	12
<i>Slides</i>	12
<i>Exit Straightener</i>	13
Lubrication	14
Parts Ordering / Replacement Rolls	14
Troubleshooting Guide	
Chain Drive	
Parts Lists	

WARNING

THIS EQUIPMENT IS DESIGNED TO BE OPERATED WITH ALL COVERS SECURED IN PLACE. OPERATION WITHOUT THESE SAFEGUARDS MAY RESULT IN CONDITIONS WHICH ARE HAZARDOUS TO THE OPERATOR AND OBSERVERS.

SAFETY GUIDELINES

Before operating the machine, study and follow the safety precautions in this section. These precautions are intended to prevent injury to you and your fellow workers. They cannot, however, cover all possible situations. Therefore, EXERCISE EXTREME CAUTION and use COMMON SENSE before performing any procedure or operation.

Safety Precautions BEFORE Starting The Machine(s)

Only one person should control the machine(s). Never allow anyone to operate the controls while you are operating or working on this equipment. In addition to disconnecting power **always use lock outs and tagouts** to prevent accidental start-up when performing maintenance procedures.

Keep your hands away from internal workings of the machinery when starting, running or stopping.

Keep your work area clean. Remove all scrap, oil spills, rags, tools and other loose items that could cause you to slip, trip and fall.

When cleaning the machine or any of its components, do not use toxic or flammable substances. Do not perform any cleaning while the equipment is running.

Never override or disable any safety switch or safety interlock.

If so equipped, make sure that hydraulic and pneumatic pressures are at specified levels before operating this equipment.

Do not operate the rollformer unless all covers and guards are in place.

Be sure that this Instruction Manual is kept near the machine so the operator can refer to it when necessary.

Keep this equipment properly maintained.

Always turn off power to the machine(s) at the main disconnect before performing any maintenance or adjustments so accidental start-up or electrocution cannot occur.

Safety Precautions WHILE Operating The Machine(s)

Never leave the work area while the equipment is in operation.

Never leave the machine unattended while it is under power or in operation.

Always be alert while operating machinery.

Be alert for loose, worn or broken parts. Do not attempt to operate any machinery with such parts present or if the machinery is making unusual noises or actions.

Avoid skin contact, prolonged breathing, or eye exposure to any stock lubrication fluid being used.

Be aware of the locations of the **Power Off** or **Emergency Stop** button in case of an emergency.

Be sure all guards and covers are in place.

Continually observe the rollforming process and related equipment. If any unusual condition develops, immediately stop and inspect the machine.

Protect yourself ! Wear safety glasses. Do not wear loose clothing, neckties, or jewelry. If long sleeves must be worn, avoid loose cuffs and buttons. Tie back and contain long hair.

Never adjust any roll feature or perform work near the rolls, gears or power take off while they are running.

General

If any pneumatic or hydraulic feature is used, disconnect the main supply and exhaust pressure and bleed the lines to prevent cycling on retained pressure.

Always shut off the power at the main disconnect switch before entering the electrical control box.

Do not use compressed air to clean the machines. Air pressure may drive dirt and small chips into the machine(s) bearing surfaces or cause bodily injury.

IMPORTANT The information contained herein is to be use as a general guide only. For further safety information obtain and read the ANSI bulletin entitled: ANSI B11.12-1996 Rollforming and Roll-Bending Machines safety Requirements for Construction, Care and Use.

**CONTACT: American National Standards Institute
11 West 42nd Street
New York, New York 10036**

WARRANTY

Our warranty on the products we manufacture is limited to repair or replacement without charge, of any part found to be defective in materials or workmanship. This warranty is for a period of one year (unless otherwise specified) from the date of shipment from our factory, for all mechanical features of the machine except purchased components that carry the warranty of the original manufacturer.

This warranty is conditioned on proper installation, maintenance and use of the equipment. The warranty will be void if the equipment is subjected to misuse or abused or if used beyond the standards in this manual, including material dimensions and gauge.

Warranty parts and components will be shipped freight collect from FORMTEK. If the defective part has not been returned to FORMTEK within 15 working days after receiving the replacement part, your company will be responsible for the cost of replacement.

The warranty provided in this clause is in lieu of all other warranties, express or implied, arising by law or otherwise, including the implied warranties of merchantability and fitness for a particular purpose which are hereby disclaimed by FORMTEK and excluded from this agreement. This warranty shall not be modified for any reason. In no event shall FORMTEK be liable for consequential or incidental damages, including the cost of assembly or disassembly, lost production or personal injury.



CAUTION

To provide clarity to points in question the illustrations and photos appearing in this manual are shown with covers and guards removed.

NEVER OPERATE THIS EQUIPMENT UNLESS ALL COVERS AND GUARDS ARE IN PLACE.

The information in this document has been reviewed and is believed to be complete and accurate. No responsibility is assumed for minor inaccuracies or content not addressed in this manual. Furthermore, FORMTEK reserves the right to make changes to any products herein, at any time, to improve reliability, function, or design. FORMTEK does not assume any liabilities arising out of any use of any product described herein, nor does it convey any license under its trade secrets or patent rights nor the rights of others.

SAFETY FIRST

Common sense and **extreme** care must be used at all times during the operation and maintenance of this equipment. It is important that ALL personnel who will operate, maintain, or supervise the use of this equipment, read and understand the sections of this manual concerning **SAFETY** and the **OPERATION** of the equipment.

The equipment described in this manual was designed and manufactured for a specific function. It should not be used for any other purpose or outside of the design specifications as this may result in damage to the equipment and/or injury to the operator. Modifications or additions to this equipment should not be made. Any such modifications or additions will void the warranty and may subject the operator to injury.

Replacement and maintenance parts must be purchased from FORMTEK or the component original equipment manufacturer. Use of other parts may result in unsafe operation or failure of the machinery. If there is a question to the suitability of a part, proper personnel FORMTEK should be consulted.

In general, every piece of equipment must be treated with extreme care. While operating or maintaining this equipment, each individual must be aware of their own safety as well as the safety of all bystanders.

SAFETY SIGN-OFF SHEET

It is the employer's responsibility to instruct all persons who may come in contact with this equipment on the safe operation and maintenance of this equipment. If a language barrier or other restriction limits understanding, this manual can be read to the individual with appropriate follow up questions to verify understanding. Have each individual sign below only after demonstrating their understanding of the safety practices described in this manual.

I verify that I have read and understand the safety and operation sections for this equipment:

NAME	DATE	NAME	DATE

SAFETY GUIDELINES



You are **NOT** ready to operate this equipment if you have not read and understood all of the safety information in this manual.



WARNING:

Do not wear loose clothing, neckties, improper gloves, or jewelry while operating this machine. If long sleeves must be worn, avoid loose cuffs or buttons, Tie back or contain long hair.

Wear proper gloves to prevent lacerations caused by sharp edges of stock as it travels through the forming operation.

Never operate this equipment unless all covers and guards are properly installed.

Be alert for loose, worn, or broken parts. Never operate this equipment unless it is in good working condition.

As the stock enters the guides and feeds into the rolls, a pinch point is created as the stock advances. Keep hands clear of area and all pinch points.

Always disconnect the main power supply power and install lock outs using a lockout / tagout procedure when making adjustments or repairs.

When transporting, take into consideration that the machine is top heavy and may suddenly tip over. The machine is designed for fixed installations and are not intended for portability.

Remember that the information contained in this manual is only a portion of an adequate training program. It must be coupled with specific instructions for your application along with full information of national and local safety regulations that may apply.

TOOLING

Standard rolls mounted on the auxiliary shafts to form a TDC duct flange profile.

OPTIONAL: TDC Clip forming rolls installed on the opposite auxiliary shafts.

INSTALLATION

Remove the machine from its shipping skids and inspect for and remove any debris that may have fallen into forming rolls, gears, chain, etc.

At the machine's operating site, level it to the floor area. Wire the machine to an appropriate power source, (voltage, phase, hertz as requested in original customer order. Machine has been wired according to these specifications and must operate on this power) meeting all electrical standards and wiring color codes for your geographical area. For further information, contact a certified electrician or the Lockformer Service Department at (630) 964-8000.

Note: The only features of the TDC rollset likely to need routine resetting are:

- The two-roll exit straightener of the TDC rolls, which may be moved up or down to control vertical bow.

OPERATING INSTRUCTIONS

OPERATION OF TDC JOINT PROFILE ROLLSET (SHOWN MOUNTED ON THE LEFT OUTBOARD SHAFTS)

Note: These instructions were written for left outboard shaft installation. If the rolls are mounted on the right side, all information will apply as an “opposite hand”.

Roll Capacity: 18-26 Ga. (1.2mm-0.6mm) Steel

Stock Width: Sheet edge operation. TDC shape uses approximately 1-7/8” (48mm) of material.

ENTRANCE GAUGE BAR SETTINGS

The entrance gauge bar ensures correct alignment of the stock when entering the starting rolls. This bar is adjustable and it is important that it is set correctly. The exact locations of the entrance gauge bar has been determined during final machine testing. An inaccurately set or loose gauge bar can feed the stock improperly. Improperly fed stock can alter the amount of material engaged in the rolls, causing poorly formed or distorted shapes, material runout, and possibly jam the material in the rolls. The entrance gauge bar location should be checked periodically for accuracy. The correct locating dimensions are set as follows:

To set the entrance gauge bar, place a straight edge along the outside face of the top rolls (against the inner faces) and extending over the entrance table. At the end nearest to the rolls, measure 2-7/16” (62mm) from the gauge bar to the straight edge, and at the end furthest from the rolls, measure 2-15/32” (62.8mm). Firmly tighten the fasteners in place. See illustration at right.

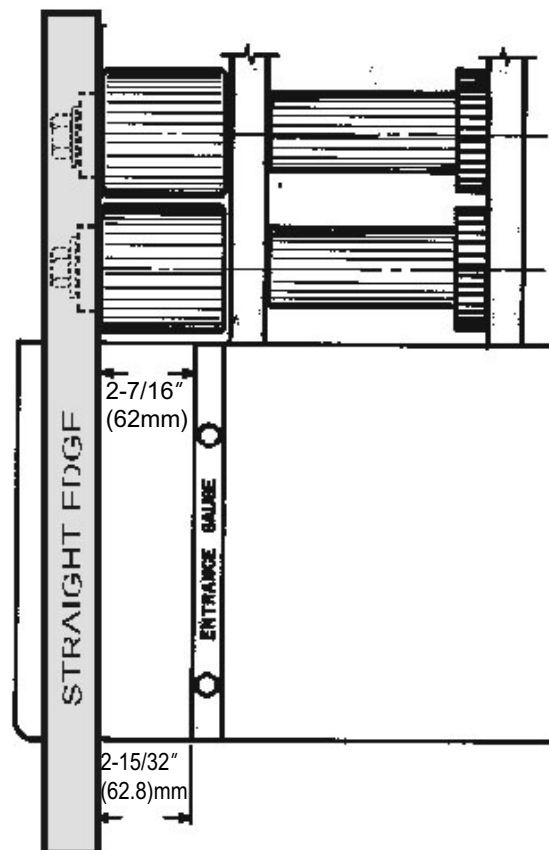
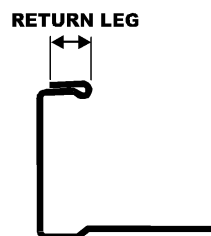

Check the fasteners frequently: they should always be firmly tightened.

The entrance gauge bar was set at Lockformer using 18 gauge (1.2mm) stock. When running lighter gauges, the return leg length will diminish slightly. If desired, the gauge bar may be moved away from the straight edge accordingly to allow more stock to enter the rolls to gain additional length to this leg.

 **CAUTION**

Reset the gauge bar to the original setting when running thicker stock.

SLIDING STOCK GUIDE (Small Parts Feeder)

The distance between the roll stations of the TDC machine may be too great for shorter pieces to be properly gripped and formed. The special Sliding Stock Guide shipped mounted at the exit end of the machine on its outboard Glide Rail is used as a movable clamp, to accommodate pieces 6-15" (150-380mm) long.

The Stock guide is used by lifting off and removing the support table assembly over which the stock ordinarily slides. With the lower Glide Rail exposed, slide the stock guide onto it at the entrance end of the machine.

To form a short piece, position it with the edge to be formed against the gauge bar and its rear edge against the back stop of the Stock Guide. Then tighten the clamp handle down to hold the piece firmly. When running heavier gauges, vise grip pliers or a "C" clamp may be used for additional grip. A heavy gauge piece must be clamped in two places to prevent pivoting.

Start the rollformer, and while holding the Stock Guide so hands remain as far from the rolls as possible, feed the stock into the rolls. Push the Stock Guide smoothly through the entire forming operation.

Remove the Stock Guide and reinstall the Support Table Assembly to return to the normal forming process.

SHEET HOLD DOWN ROLL ASSEMBLY

The Sheet Hold Down equipped with rubber rollers helps control the tendency of the panel to bend upwards as it is rollformed. These rollers have been factory set.

The roll's mounting plate may be raised or lowered (respectively) by simply loosening its mounting screws, raising or lowering it in small increments, as desired, and tightening the mounting screws. If 18 (1.2mm) gauge stock does not form a satisfactory right angle, lower or raise these rolls slightly to alter the roll's downward pressure. Less pressure will open the "90° angle" and more pressure will close the angle. Test each new setting with care, as setting the rollers too low could impair the sheet's freedom of movement.

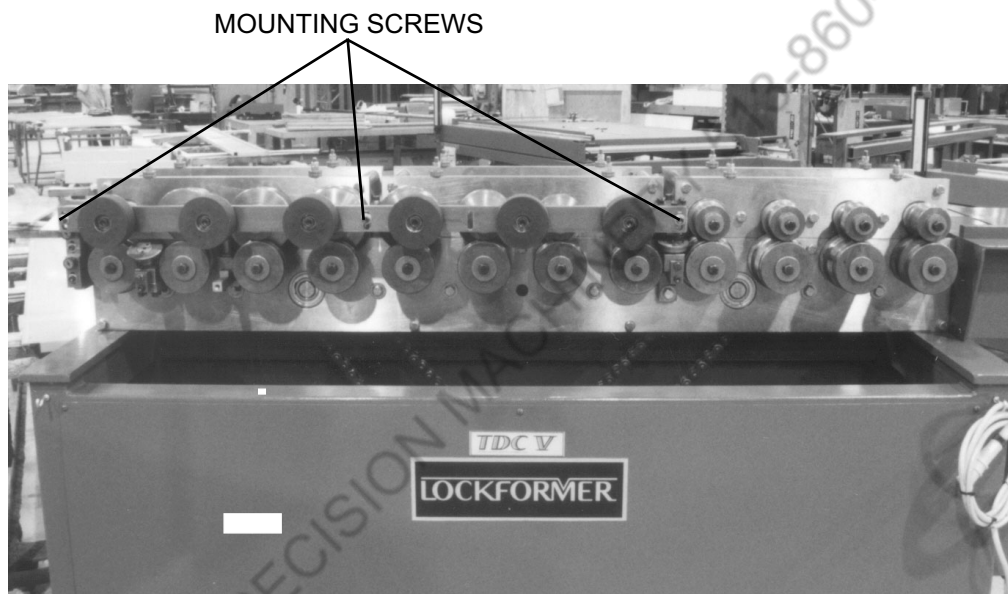

STUD NUT ADJUSTMENT

The upper machine plates are designed to float within an adjustable range of vertical travel. The stud nuts (one stop nut, one jam nut) are located on top of the studs running through the upper machine plates. These nuts are placed upon a series of spring (Belleville) washers. See the illustration on the next page for their stacking arrangement.

The purpose of this spring loaded design is to compensate for variations of metal thickness by self-adjusting the horizontal clearance between the top and bottom mating rolls.

By tightening the stud nuts, the vertical travel of the upper rolls is lessened and the horizontal clearance is reduced. Less horizontal clearance increases rollgrip, tightens the formed profile and the inside corner radii.

Exact stud nut settings have been determined during final testing of the machine. See the photo below for each gauge being run.

NOTE: If the stud nuts are set too tight, the stock will jam in the rolls!

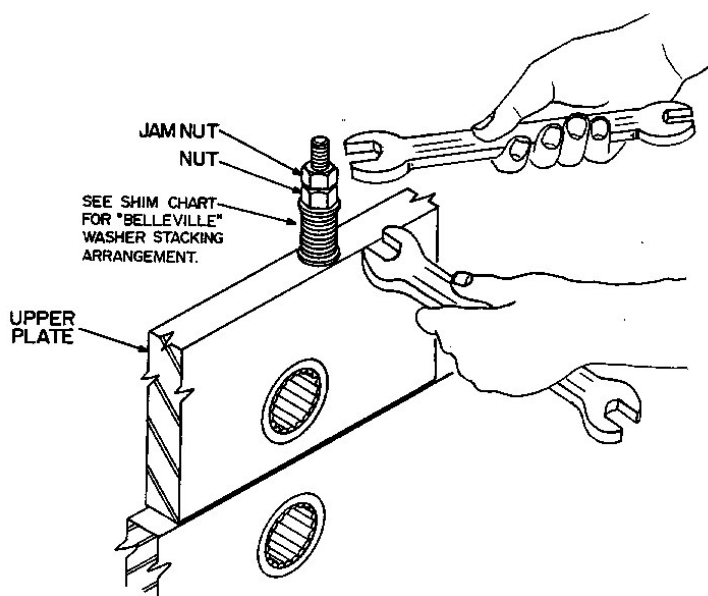

1. LOOSEN JAM NUT SEVERAL TURNS, THEN TIGHTEN THE REGULAR NUT UNTIL SNUG.
2. LOOSEN THE REGULAR NUTS AS SHOWN ON THE PHOTO.
3. TIGHTEN THE JAM NUT AGAINST THE REGULAR NUT. (USE TWO WRENCHES...ONE TO MAINTAIN THE POSITION OF THE REGULAR NUT, AND ONE TO TIGHTEN THE JAM NUT.)

26 (0.6mm), 24 (0.8mm), 22, and 20 (1.0mm) gauge = fully tighten the stud nut
18 gauge (1.2mm) only = fully tighten, then loosen 2-1/2 to 3 turns

remains snug for all gauges

1/8 turn loose for all gauges

1/2 turn loose for all gauges

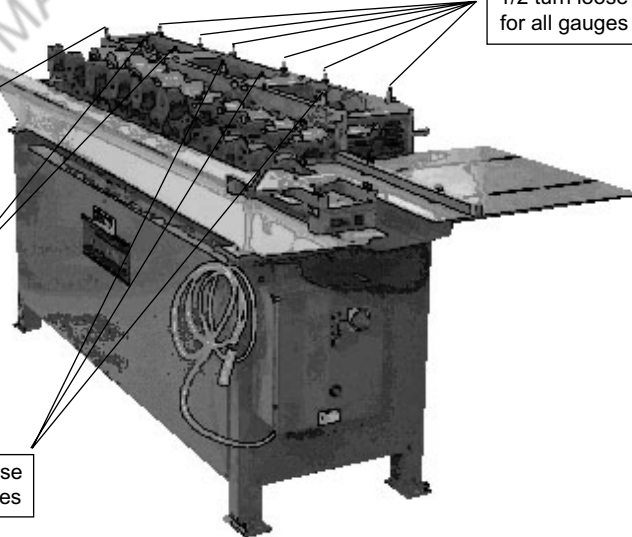

CINCINNATI PRECISION MACHINERY 733

SHIMS BETWEEN MACHINE PLATES

The shims, located on the vertical studs between the upper and lower machine plates help control the effective vertical distance between the top and bottom rolls.

Each dowel pin and stud is supplied with one shim. All shims on the machine will be either 0.10"(0.25mm) or 0.015" (0.4mm).

If the machine is ever disassembled, it is important that all of the shims are replaced when reassembled.

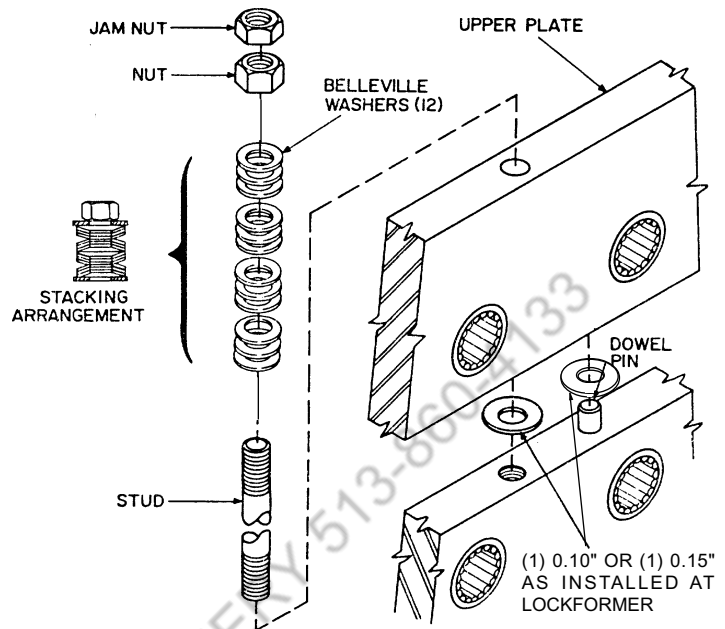

ALWAYS JOG STOCK PAST FEATURES THAT HAVE BEEN RESET TO TEST THE NEW SETTINGS

IDLER ROLLS

When forming some profiles it is common that only the main forming rolls are needed to provide desired results. However, many rollforming applications can be done more efficiently by adding idler rolls either between roll stations or directly on the roll station itself.

Maintaining angularity of bends, opening of thin clearance sections, guiding of stock into next operations, and maintaining straightness are but a few conditions controlled by idler rolls. For this rollset, idlers have been installed between stations 4-5 and 11-12.

It is important that the material clearance dimension between the mating rolls allows the material to move freely and still be formed correctly. **Both idler assemblies have been factory set to form all gauges properly, so readjustment should seldom, if ever, be necessary.** If these settings are disturbed so that they need to be returned to original settings, the following procedure should be used:

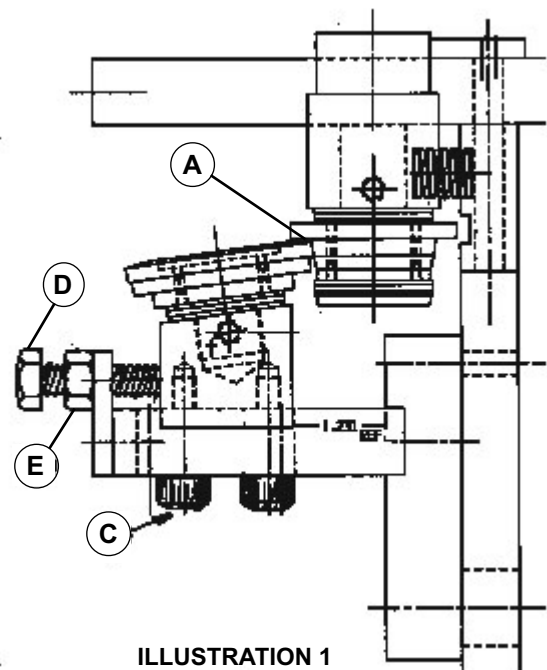

ILLUSTRATION 1

IDLER AT STATION 4-5

The inner idler (nearest to the machine plate) is spring loaded and a stop plate is bolted into place behind it to prevent the roll from moving more than the proper amount of clearance. This spring loaded idler is designed to self-adjust when running different thicknesses.

IDLER ROLLS (CONT)

The lower, outer idler was factory set at 1.231" (31.26mm) between its edge and the mounting bracket for all stock thicknesses. This setting should not require changing, and the roll should remain as located, reset only if problems arise. If for example the corner radius at **(A)** loses its sharpness, loosen the locking screws marked **(C)** and the adjustment screw jam nut marked **(E)**, and position this assembly at 1.231" (31.26mm) out. Now turn the positioning screw **(D)** to move the idler inwards to 1.226" (31.14mm), then retighten the jam nut. Run a test piece and check the results. If the corner is still loose continue to move the idler in no more than .005" increments until satisfactory results are obtained. See reference dimensions shown in illustration 1.

IDLER AT STATION 11-12

The idler assembly at stations 11-12 has been factory set for the heaviest gauges. The outer idler is mounted in a spring loaded bracket and rests against the inner roll until the stock passes between them. The outer positioning screw **(G)** was tightened so its end was up against the idler block, then loosened by one full turn. See illustration. Due to inconsistencies of the physical properties of the steel being run, it may be necessary to tighten the positioning screw in very fine increments to tighten the corner radius **(A)** to achieve an accurate bend angle.

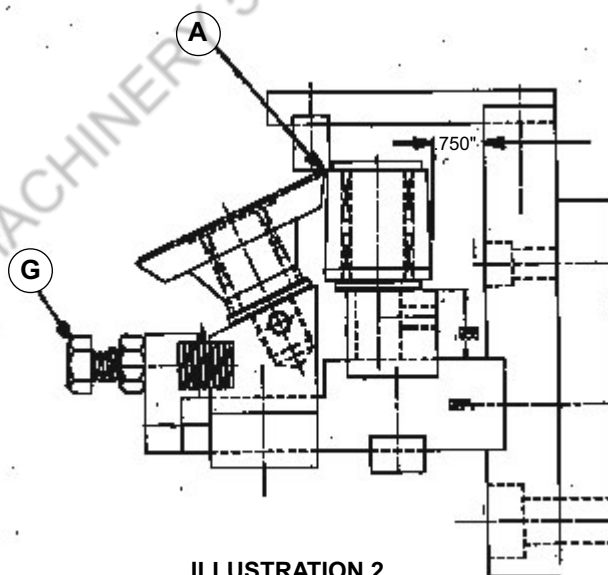

ILLUSTRATION 2

! CAUTION

Always make adjustments in very small increments. If the clearance dimension is set too tight, a stock jam-up may occur causing possible damage and unnecessary downtime of machine.

EXIT STRAIGHTENER

The exit straightener mounted to the machine plate after the final forming rolls is designed to control any tendency of the stock to bow up or down. This bracket has two idler rolls set at a fixed distance apart, so that the profile passes between them. The bracket itself is slotted so the rolls may be raised or lowered together as needed to correct up or down bow.

NOTE: Machines are generally shipped with this device set to straighten thicker stock, so it will probably be necessary to reset it to straighten thinner stock.

To achieve optimum straightness, adjust the straightener as follows:

If part bows up or down, raise or lower the unit as required, **in the opposite direction of bow**. First loosen the two lockscrews **A** slightly, then raise or lower the roll bracket in very small increments. Tighten the lockscrews after the adjustment is made.

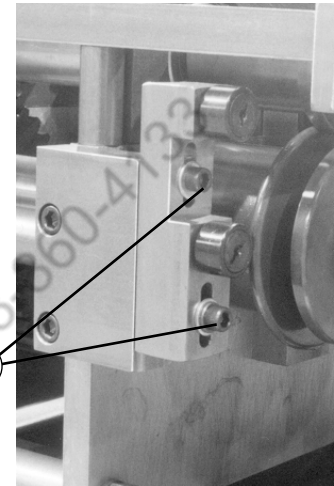

OPERATION OF OPTIONAL TDC CLIP ROLLS MOUNTED ON THE OUTBOARD SHAFTS

Note: Stamped numbers of Clip Rolls (in right outboard position) must face outward, towards Installer. If such rolls must ever be installed at right outboard position, be sure to orient them this way

Roll Capacity: 0.24-0.30" (0.6mm-0.8mm) Galv. Steel (This thickness is critical)

Stock Width: 2.125 inches (57.15mm)

CINCINNATI PRECISION CHINERY 513 860-4133

ENTRANCE GAUGE BAR SETTINGS

The entrance gauge bars mounted on the table ensure correct alignment of the stock while entering the starting rolls. These bars are adjustable and it is important that they are set correctly. The exact locations of the entrance gauge bars have been determined during final machine testing. Inaccurately set or loose gauge bars can feed stock improperly. Improperly fed stock can alter the amount of material engaged in the rolls, causing poorly formed or distorted shapes, material runoff, and possibly jam the material in the rolls.

The entrance gauge locations should be checked periodically for accuracy. The original reference dimensions are determined as follows:

Place a straight edge on the outside face of the rolls (not spacers mounted on shafts beside them), extending over the entrance table. Measure 2-9/16" (65mm) from the straight edge to the end of the bar nearest the rolls and 2-19/32" (66mm) from the straight edge to the end of the bar furthest from the rolls, and lock bar in place at this position to feed stock at a slightly tapered angle. Set the right gauge bar stock width 2.125" (54mm) (parallel) away. See illustration.

Check fasteners frequently: they should always be firmly tightened.

NOTE: shows precise specifications of the piece to be produced by these rolls. Before installation, check clip against this print to determine accuracy of these three dimensions, which are critical (within tolerance):

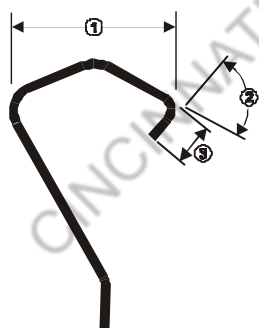

- ① 13/16" (20.6mm) top overall width
- ② 78° angle of top right bend
- ③ length of 13/64" (5.16mm) leg

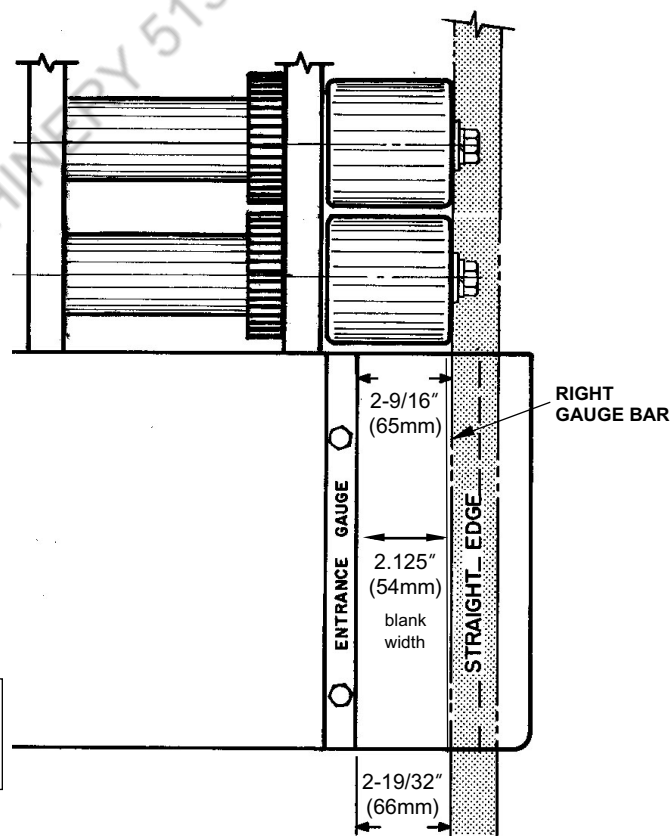

If these sections are formed inaccurately, installation may not be affected, but clip may not hold reliably.

These dimensions may be corrected by changing the tension of the stud nuts (in gradual increments) at stations 5 and/or 6 to loosen or tighten profile, as necessary. If the 42°, 13/64" (5.2mm) final leg is formed too long and a reinforcing bar is used, installation onto the TDC flange may be difficult. If it is too short, the clip may not be held in place. The length of this leg may be adjusted as desired by moving the gauge bars slightly (but maintaining blank width distance between them). This will engage more or less stock in the rolls, changing the length of this leg as needed. Using stock thinner than the tolerance dimension may also cause inaccurate forming.

STUD NUT ADJUSTMENT See page 8.

SHIMS BETWEEN MACHINE PLATES See page 9.

ROLLSHIMS AND SPACERS

Spacers are placed only on the outside face of the rolls. These rolls, spacers and any shims that may have been placed on the shafts with them must be reinstalled in their original positions if the chassis and its components are ever separated.

EXIT STRAIGHTENER

As the material passes through rollformer, stresses can be cause by the bending process causing the finished part to bow as it exits the machine. The straightening unit attached to the exit table is used to eliminate bowing.

The straightener is designed to fit the contour of the formed piece and is adjustable vertically and laterally.

The straightener operates on a principal of counteracting the force causing the bow, by moving the unit in the opposite direction of the bow.

For example, if the part emerges with a down bow, the unit should be raised. If the part emerges with a side bow to the left, the unit should be moved to the right, etc.

This straightener has been factory set at an angled position to compensate for a side bow, and it is recommended that this position only be changed in very small increments. The idler roll on the exit straightener can also be adjusted up or down to reduce a vertical bow by turning the adjustment screw in fine increments until the desired result is obtained. If range of adjustment does not improve part straightness proceed as outlined in the following paragraph, then fine adjust with roll.

Raising the straightener to control a down bow can be done in small, gradual increments by raising the table, placing shims under the exit end of the straightener or turning to jacking screws (if present) beneath it until satisfactory results are achieved. To correct an up bow by lowering the

straightener, it may be necessary to lower the table, unless shims can be removed or an upward jackscrew setting lowered to move the straightener down.

To achieve optimum straightness, adjust as follows:

If part bows laterally (A) or (B), move unit in the opposite direction of the bow.

Example: If part bows to the right, (A) (as viewed from the entrance of the machine), move straightener to the left in small increments, testing results after each adjustment, until satisfactory results are obtained.

If part bows up or down, raise or lower idler roll as required, in opposite direction of bow. First loosen locknut on thumbscrew (C), then adjust by turning thumbscrew. Tighten locknut after adjustment is made.

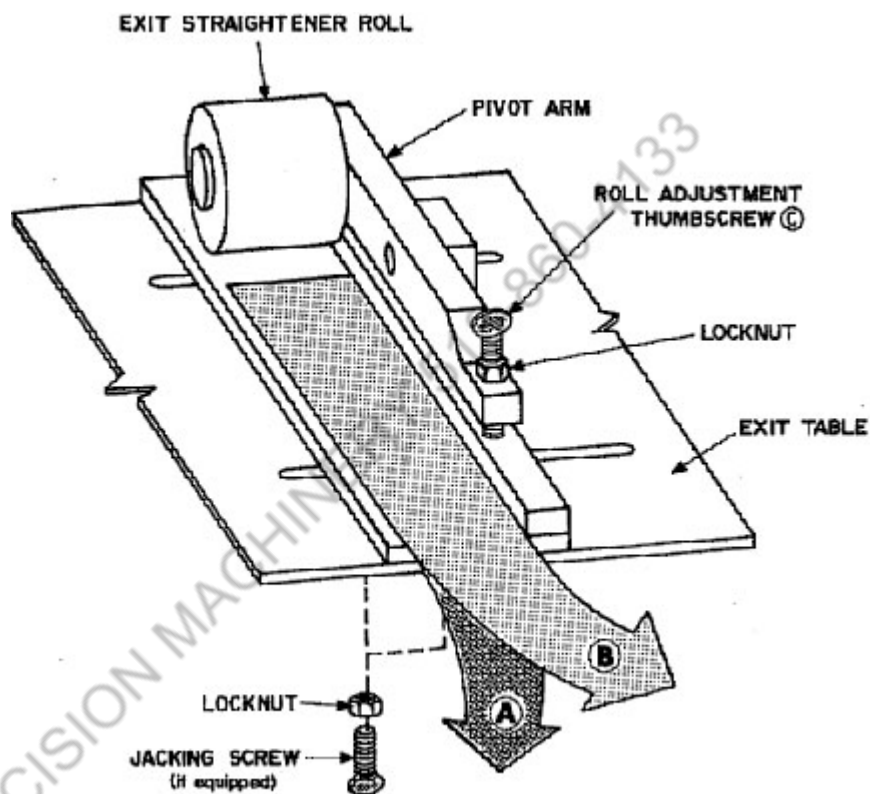

LUBRICATION

A good preventative maintenance program is a major step forward in assuring trouble free machine operation. In order to be effective, routine inspection, lubrication and adjustment schedules should be established and followed.

Use of lubricants other than that which is supplied in the machine may prove to be incompatible and cause severe damage to the machine. Lockformer uses **Castrol Molub Alloy 777-1 ES** grease. It provides excellent lubricating qualities in all rollformer applications. If a substitute grease is used, check with its manufacturer to be sure that it is formulated to be compatible with **Castrol Molub Alloy 777-1 ES**.

Due to clearance limitations the idler rolls do not have a lubrication fitting permanently installed. Each idler pin has been provided with a tapped grease fitting. Some disassembly may be required to gain access to this area. After applying grease to the bearing, **remember to remove this grease fitting**.

Apply grease to all gear teeth regularly to help eliminate noise and galling of gears every 40 hours. Apply a liberal amount of light oil to the bronze thrust washers, located on the roll shafts, every 80 hours.

Apply light oil to all load carrying areas of the drive chains every 80 hours

RECOMMENDED LUBRICANTS

Castrol.....Tribol Molub Alloy 777-1 ES

GEAR BOX

Oil Capacity

To insure proper the operation of the gear reduction unit always maintain the proper oil level. The unit provided (RV130-30) should be filled to the oil level check hole.

Servicing

The gear box manufacturer recommends that the oil be changed after the first 400 hours of operation and every 4000 hours thereafter. If any leakage is detected the unit should be serviced immediately.

Oil Types	NMRV, NRV 110-150 Mineral Oil	
Temperature (F°) ISO VG	23° - 75° 460	5° - 77° 220
Oil Brand		
AGIP	Blasia 460	Blasia 220
Shell	Omala Oil 460	Omala Oil 220
Esso	Spartan EP460	Spartan EP220
Mobil	Mobilgear 634	Mobilgear 630
Castrol	AlphaMax 460	AlphaMax 220
BP	Energol GR-XP460	Energol GR-X320

MACHINE PARTS ORDERING

If ever ordering machine parts, please specify on the order: For TDC V machine (including machine serial number marked on machine).

REPLACEMENT ROLLS

If ever ordering replacement rolls, please give all the information stamped on the side face of rolls.

CINCINNATI PRECISION MACHINERY 513-860-4133

Due to continuous improvements, FORMTEK reserves the right to modify the product

design and specifications contained herein without notice. Please contact your Lockformer sales representative for the most current specification information.

Use, publication, or sale of any images or content without the expressed written consent of FORMTEK is strictly prohibited.

Visit Our Web Site at:
WWW.lockformer.com
or www.formtekinc.com

