

INSTALLATION and
OPERATING INSTRUCTIONS

LOCKFORMER

**BUTTON PUNCH
CHEEK BENDER**



THE LOCKFORMER COMPANY

711 W. OGDEN AVENUE • LISLE, ILLINOIS 60532

Operating Instructions

CAPACITY: 20 Gauge or lighter galvanized or cold rolled steel.

OPERATION: 1. Start unit and operate several times with no material in the machine to bleed all air from the system.

2. Insert material into die opening and depress foot switch to actuate die and form flange and buttons. Release foot switch and remove completed flange. Reinsert cheek on opposite side of die and actuate die. Proceed as above until all (4) edges of cheek are completed.

CAUTION: Release foot switch immediately after flange is formed. If foot switch is kept depressed oil pressure will be at maximum setting of relief valve and will cause unnecessary heating of oil and possible damage to pump.

3. On pieces longer than 24", it will be necessary to slit the flange edge at 24" intervals as illustrated in Figure NO. 4.

Proceed as in paragraph #2 making bends in 24" increments.

4. Due to the design of the hydraulic system, when using this unit with the Speednotch Power Package, it is necessary to regulate the flow of the hydraulic oil. A flow control valve is furnished in the Tee connection of the Main Assembly. (See Figure NO. 5) To decrease the operating speed of the bender, turn the adjusting screw counter-clockwise. Once a satisfactory speed has been attained, lock the adjusting screw in place with the lock nut.

HYDRAULIC UNIT MAINTENANCE:

For proper maintenance of the hydraulic system, the oil should be kept clean and free from dirt or other foreign matter. The suction strainer located in the reservoir should be removed and cleaned periodically. The system should be changed after approximately one year's operation and refilled with clean filtered oil. (See paragraph for recommended oil.)

GENERAL MAINTENANCE

Occasionally a light oil should be applied to the surface the upper die slides on. Also a light oil should be applied to the cutting surface of punch and die to prolong the die life.

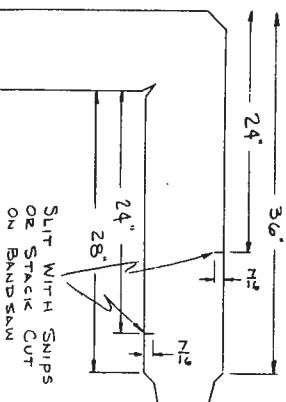

Figure NO. 4
Typical Large
Cheek example

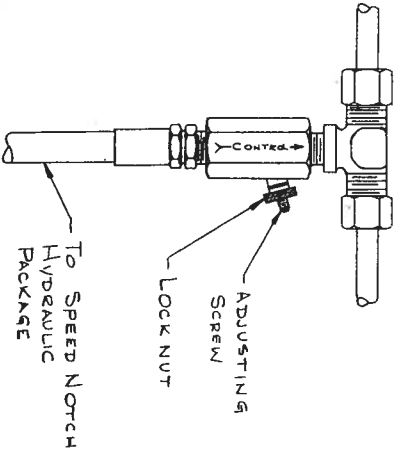
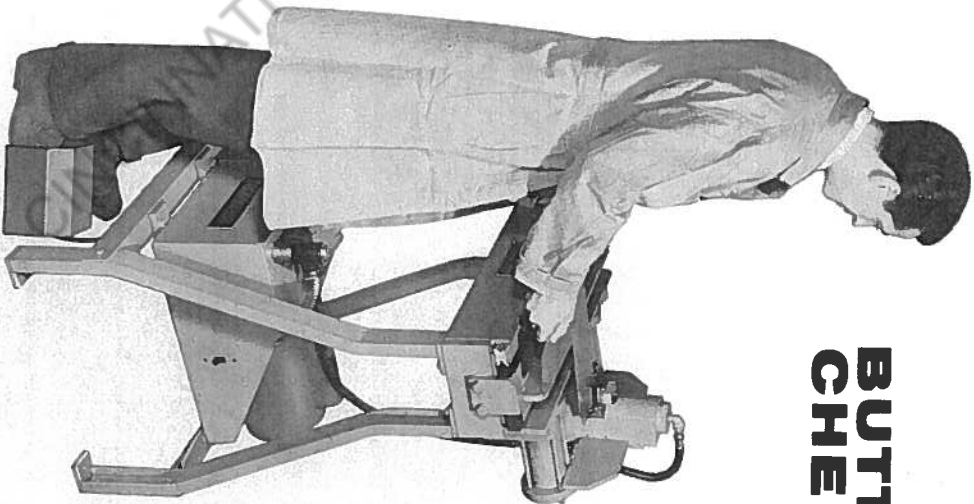

Figure NO. 5

INSTALLATION and OPERATING INSTRUCTIONS

LOCKFORMER

BUTTON PUNCH CHEEK BENDER



THE LOCKFORMER COMPANY

711 W. GARDEN AVENUE • DEERFIELD, ILLINOIS 60015

GENERAL ASSEMBLY

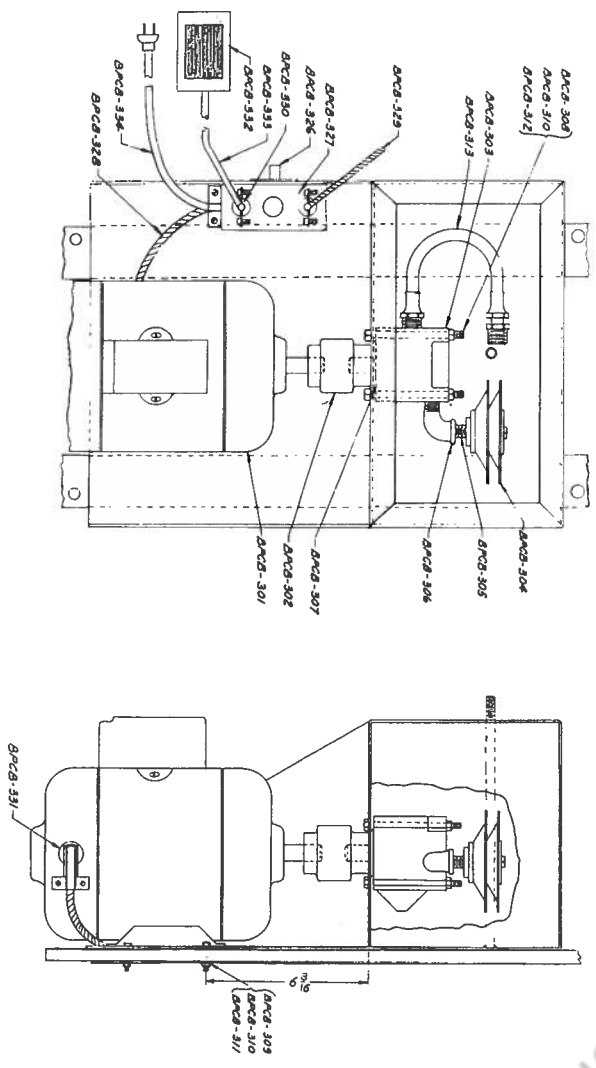
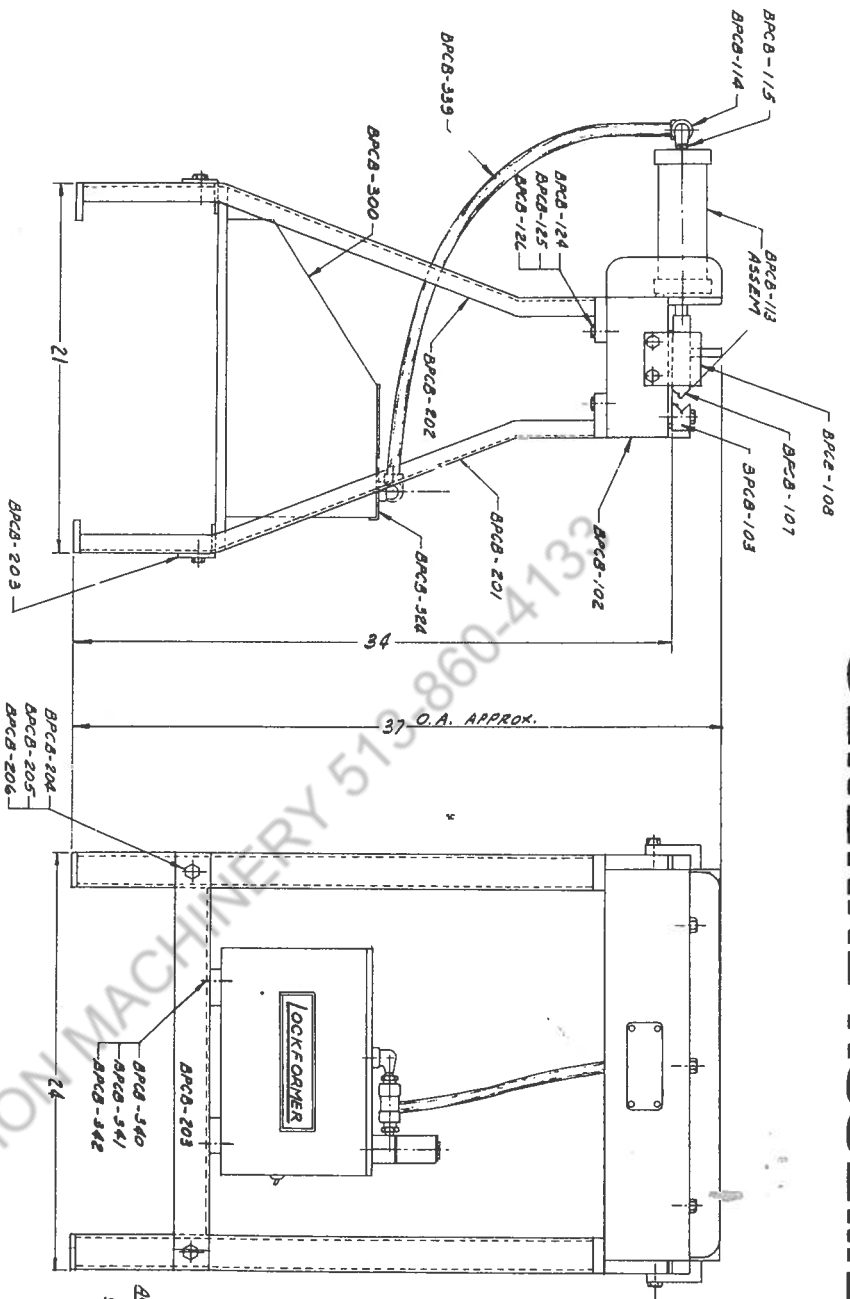

ACTUAL W.T. = 285^g
CAPACITY = 20.64

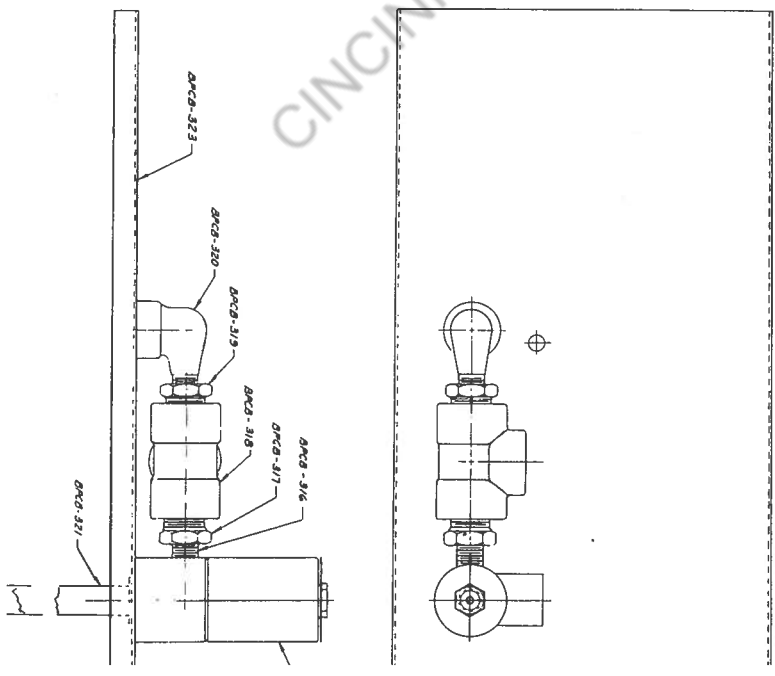
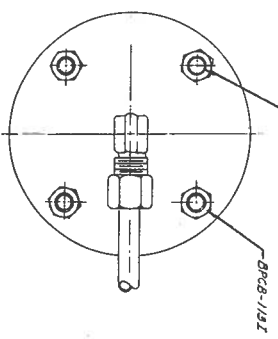
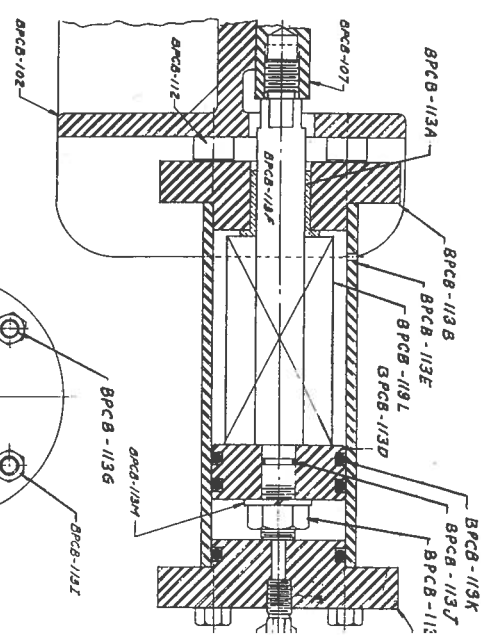

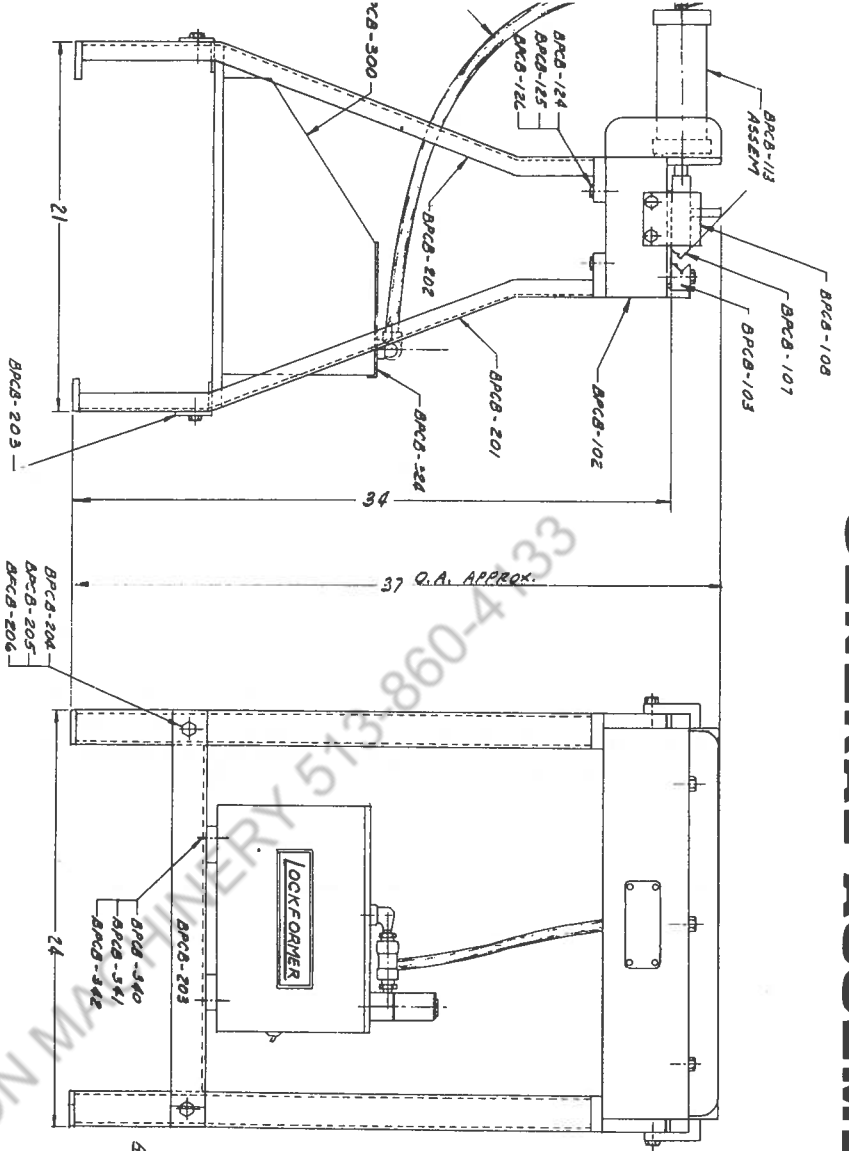

ACTUAL W.T. = 28.5[±]
 CAPACITY = 20.6A

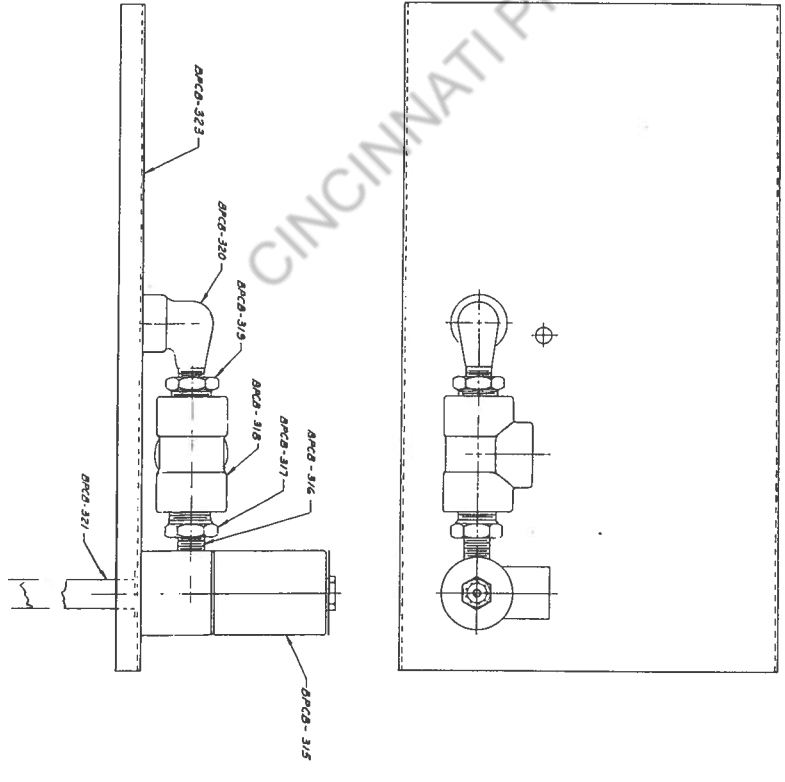
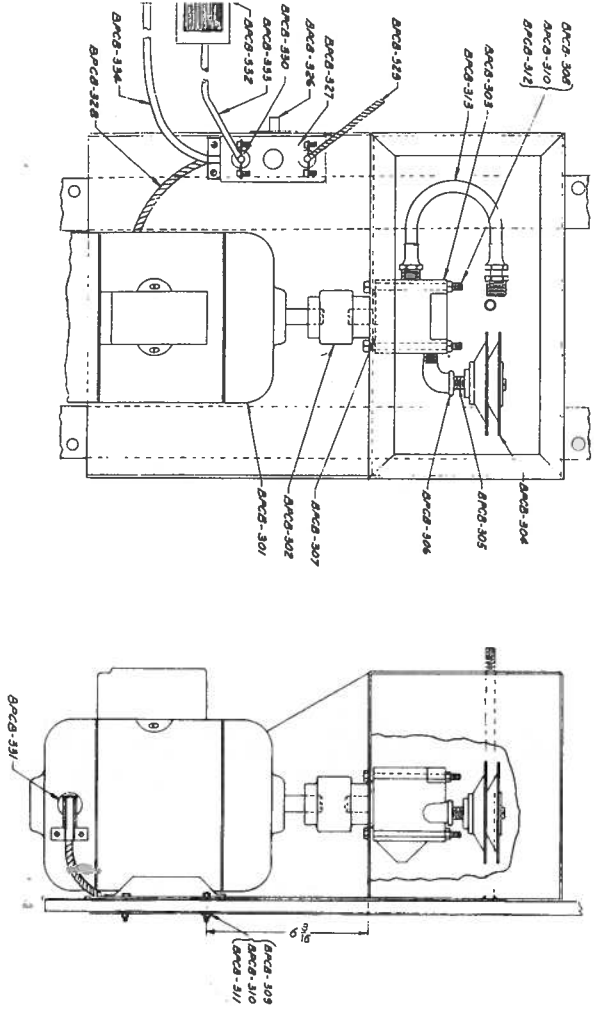
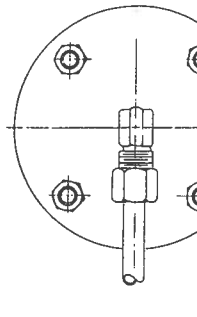
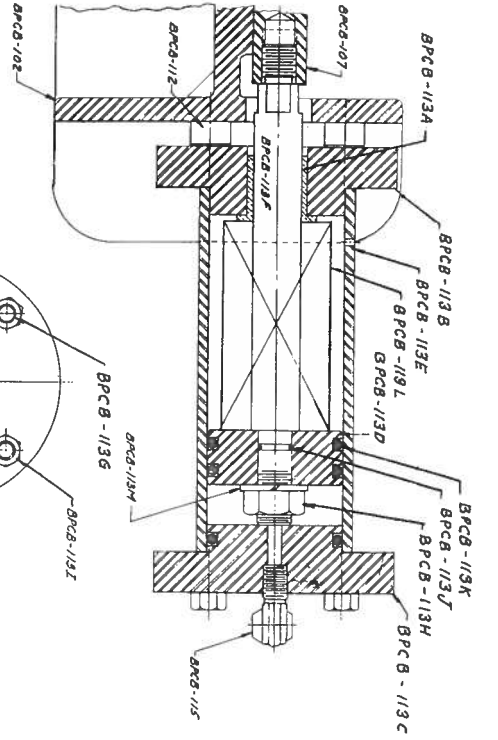

CINCINNATI PRECISION MANUFACTURING 513-860-4133

PARTS LIST and DESCRIPTION

USE NEW
NUMBER
WHEN ORDERING
PARTS



New Part No.	Old Part No.	Description	Pcs. Per Unit	New Part No.	Old Part No.	Description	Pcs. Per Unit
56509	BPCB-102	Main Base	1	60091	BPCB-204	Hex Cap Screw	4
22315	BPCB-103	Lower Die	1	62363	BPCB-205	Lock Washer	4
19002	BPCB-104	Punch	15	61120	BPCB-206	Hex Nut	4
60097	BPCB-105	3/8" - 16 Hex Head Cap Screw	3	0400301	BPCB-300	Hydraulic Power Unit Complete	1
62363	BPCB-106	3/8" Lock Washer	3	80041	BPCB-301	1 H.P. Motor	1
56529	BPCB-107	Upper Die	1	70801	BPCB-302	Coupling	1
28800	BPCB-108L	Hold-Down Left Hand	1	65403	BPCB-303	Pump	1
28801	BPCB-108R	Hold-Down Right Hand	1	65675	BPCB-304	Suction Strainer	1
60152	BPCB-109	1/2" - 13 x 1-1/4 Hex Head Cap Screw	4	65026	BPCB-305	3/8" Close Nipple	1
62364	BPCB-110	1/2" Lock Washer	4	65183	BPCB-306	Street Elbow	1
62057	BPCB-111	1/2" I.D. Washer	4	65600	BPCB-307	Gasket	1
13501	BPCB-112	Spacer	8	65800	BPCB-308	Compression Washer	4
9954411	BPCB-113	Cylinder Ass'y. Complete	2	60047	BPCB-309	Hex Cap Screw	4
66401	BPCB-113A	Bearing	2	61101	BPCB-310	Hex Nut	8
15162	BPCB-113B	Rod End Cap	2	62362	BPCB-311	Lock Washer	4
15161	BPCB-113C	Piston End Cap	2	60053	BPCB-312	Hex Cap Screw	8
15124	BPCB-113D	Piston	2	65704	BPCB-313	Hose Ass'y.	1
15166	BPCB-113E	Cylinder Body	2	65530	BPCB-315	Solenoid Valve	1
15104	BPCB-113F	Cylinder Rod	2	65026	BPCB-316	3/8" Close Nipple	1
14854	BPCB-113G	Tie In Rod	8	65112	BPCB-317	Reducing Bushing	1
61203	BPCB-113H	Nut	2	65275	BPCB-318	1/2" Tee	1
61120	BPCB-113I	Nut	8	65113	BPCB-319	Reducing Bushing	2
65625	BPCB-113J	"O" Ring	2	65176	BPCB-320	1/4" Street Elbow	1
65646	BPCB-113K	"O" Ring	6	65025	BPCB-321	Tank Nipple	1
71017	BPCB-113L	Spring	2	54400	BPCB-322	Tank Ass'y.	1
62365	BPCB-113M	5/8" Lock Washer	2	54422	BPCB-324	Cover Ass'y.	1
66630	BPCB-114	Female Side Tee	1	80205	BPCB-326	Starter Switch	1
66623	BPCB-115	Male Elbow	2	80651	BPCB-327	Junction Box	1
15165	BPCB-116	Tubing	2	80430	BPCB-328	BX Cable	1
65717	BPCB-118*	Coupler	1	80704	BPCB-329	Greenfield Cable	1
65003	BPCB-119*	Nipple	1	80481	BPCB-330A	BX Connector 1/2"	2
65550	BPCB-122*	Flow Control Valve	1	80483	BPCB-330	BX Connector 3/8"	3
65000	BPCB-123*	Close Nipple	1	80485	BPCB-331	90° Connector	1
60091	BPCB-124	Hex Cap Screw	4	80209	BPCB-332	Foot Switch	1
62363	BPCB-125	Lock Washer	4	80525	BPCB-334	Power Cord Set	1
61120	BPCB-126	Hex Nut	4	65700	BPCB-339	Hose Ass'y.	1
0400201	BPCB-200	Stand Ass'y. Complete	1	60094	BPCB-340	Hex Cap Screw	4
56581	BPCB-201	Right Hand Leg.	2	62363	BPCB-341	Lock Washer	4
56582	BPCB-202	Left Hand Leg.	2	61120	BPCB-342	Hex Nut	4
29405	BPCB-203	Cross Angle	2	45000	BPCB-345	Pipe Plug	1

*Furnished Only When Speednotch Power Package Is Used.

INSTALLATION PROCEEDURE

PRELIMINARY: For convenience in shipping, the unit is shipped knocked-down. Before attempting assembly be sure to read the Assembly Instructions Completely.

ASSEMBLY

INSTRUCTIONS: 1. Begin stand assembly by bolting the cross-angles to the Leg Assemblies as illustrated in Figure NO. 1 using the 3/8-16X1" LG. Hex Bolts, Lockwashers and Nuts provided.

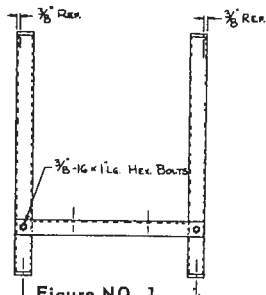

Figure NO. 1
Assembly Detail
of Stand

2. Place the Hydraulic Power Package Assembly in place on the stand cross-angles as illustrated in Figure NO. 2 using 3/8-16X1-1/4" LG. Hex Bolts, Lockwashers and Nuts provided.

3. Place the Check Bender Main Assembly in place on top of the stand as illustrated in Figure NO. 2 and fasten using the 3/8-16X1" LG. Hex Bolts and Lockwashers provided.

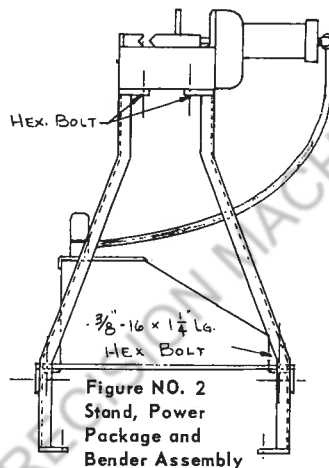

Figure NO. 2
Stand, Power
Package and
Bender Assembly

4. Connect Hydraulic Hose from power package to Tee connection on Main Assembly. See Figure NO. 3. NOTE: If Cheek Bender is to be used with Speednotch Hydraulic package, remove plug from sixth hole of manifold and screw nipple on end of hose from the main assembly into the manifold.

5. Unbind foot switch cord and power cord.

IMPORTANT: Because of shipping requirements and possible spillage of Hydraulic Fluid, the unit is tested at Lockformer's Plant and the Hydraulic Fluid is drained. Therefore, it will be necessary to fill the unit before start-up.

Before attempting to run unit, fill reservoir with 3-1/2 gallons of a commercial hydraulic oil having a viscosity of 150 SSU @ 100°F. An acceptable substitute for the above hydraulic oil is type A Automatic Transmission Fluid, available at auto service stations. A ruler inserted to the bottom of the reservoir will indicate 7-1/2" when the proper oil level is reached.

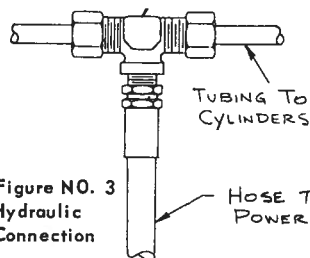

Figure NO. 3
Hydraulic
Connection

ELECTRICALS: Normal electrics 110 Volt, 60 Cycle, Single Phase. Motor furnished 1 H.P. x 3600 RPM. Full load amps 11.8. Check local code restrictions for electrical service required.