

GENERAL OPERATING INSTRUCTIONS AND PARTS LIST

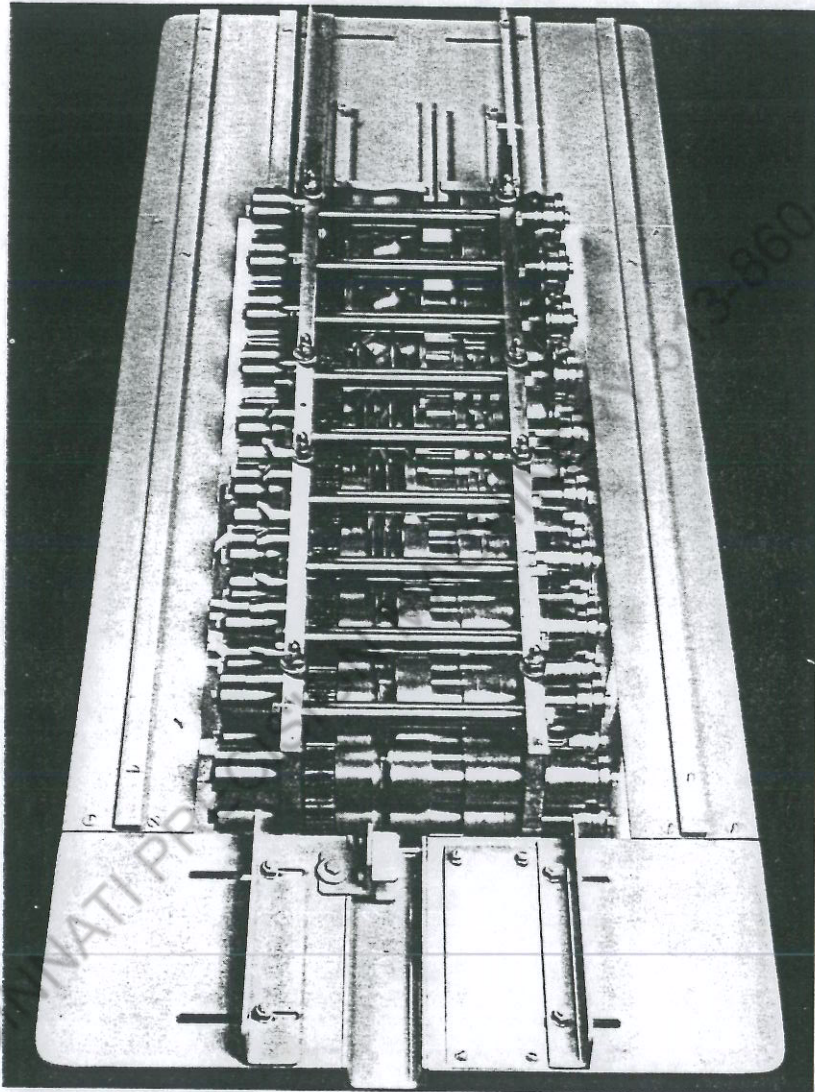

HIGH SPEED QUADFORMER

flagler

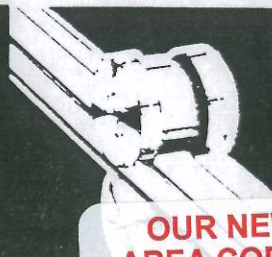

DESIGNERS
AND
MANUFACTURERS
OF
ROLL FORMING
AND RELATED
EQUIPMENT

OUR NEW
AREA CODE IS
586

GENERAL INSTRUCTIONS AND PARTS MANUAL

FLAGLER HIGH SPEED QUADFORMER

ELECTRICALS:

5 H.P. 220/440/3/60 motor and controls. Standard machine wired for 220 volts unless otherwise specified.

OPERATION:

When machine has been wired to correct power source, check rotation. When rotation has been determined, place properly sheared blank between gage bars and feed material into the rolls. Check the end result and make changes accordingly.

ADJUSTMENTS:

Should the machine labor under load, the hold down studs are set too tight. To readjust, tighten the eight studs that pass through the machine plates and then loosen approximately one quarter of a turn (90°). Should the machine continue to labor, loosen the four studs on the lead end of the machine to three-eighths (135°) or one-half turn (180°). Downward bow can be compensated for by adjusting the hold down studs located at the exit end of the machine. Side bow is caused by an imbalance in the stud adjustment.

LUBRICATION:

Lubrication fittings for the high speed shafts are located on the side panel through a central lubrication system. The high speed bearings should be lubricated every eight hours of operation. A coating of good open gear grease should be kept on the gears at all times.

NOTE: If the machine is to be used or stored out-of-doors, an oil or grease film will prevent rusting of all surfaces.

INSTRUCTIONS FOR MOUNTING AUXILIARY ROLLS:

Machine auxiliary shafts are designed to accommodate various auxiliary rolls listed below. To install these rolls, proceed as follows:

1. Remove the section of the table top side plate on the side of the machine which the rolls are to be mounted.
2. If auxiliary rolls are now on the machine, remove the retaining bolts and washers. Remove all parts not pertaining to the set to be used.
3. Place all Woodruff Keys in proper location.

4. Select the first pair of rolls which are marked "T-1" and "B-1" and place them on the shaft at the entrance end of the machine. Place the "T-1" roll on the upper shaft and the "B-1" roll on the lower. Repeat procedure through all roll stations.

All rolls marked "T" should be mounted on the top shaft and the "B" rolls mounted on the bottom shaft in numerical order. NUMBERED SIDE OF ROLLS MUST FACE OUTWARDS.
5. After the rolls are installed, fasten the rolls with retaining screws and washers.
6. Mount entrance and exit gages to the stand, using the slotted holes provided in the table top. Set entrance gages by placing a straight edge along the outer edge of the auxiliary rolls, measure to the required amounts in from the straight edge to the extreme ends of the entrance gage.

MAXIMUM MACHINE CAPACITY:

Center position must be factory installed and is not interchangeable.

Reinforced "S" Cleat	- 22 ga.
Drive Cleat 1-1/8"	- 20 ga.

AUXILIARY MOUNTED ROLLS:

	<u>Capacity</u>
Tap-In-Lock (1/2" or 5/8")	-22 ga.
Pittsburgh Lock (5/16" or 3/8")	-20 ga.
Acme Lock (3/8" or 1/2")	-20 ga.
Standing Seam (3/4")	-20 ga.
Right Angle Flange	-20 ga.
Reeves Lock	-26 ga.
Modified Reeves Lock	-24 ga.
Pittsburgh-Type Button Lock	-24 ga.
1/2" Button Lock	-20 ga.
3/8" Button Lock	-26 ga.
5/16" Slip Lock	-26 ga.
180° Hem Rolls	-20 ga.

PARTS LIST

FOR

FLAGLER HIGH SPEED QUADFORMER MACHINE

<u>NEW PART NO.</u>	<u>DESCRIPTION</u>	<u>AMOUNT REQ'D.</u>
21-001	BOTTOM FRONT PLATE	1
21-002	BOTTOM BACK PLATE	1
21-003	TOP FRONT PLATE	1
21-004	TOP BACK PLATE	1
23-001	#1 PINION GEAR	1
23-002	#2 PINION GEAR	1
17-008	PINION COLLAR	2
17-062	PINION COLLAR W/KEYWAY	1
17-009	BULL GEAR	1
17-014	DRIVER IDLER GEAR	1
23-007	LONG STEP SPACER	1
17-013	IDLER GEAR	8
23-006	PLAIN STEP SPACER	8
17-012	ROLL SHAFT GEAR	20
23-026	ROLL SHAFT SPACER	40
23-003	ROLL SHAFT	20
23-005	PLAIN SPACER	14
17-058	BEARING B-1612 (ROLL SHAFT)	40
12-021	BEARING B-148 (IDLER GEAR)	16
14-021	BEARING B-1412 (DRIVER IDLER GEAR)	2
20-005	BEARING HJ-162412 (PINION GEAR)	4
17-059	HOLD DOWN STUD 3/8 - 16 x 6	8
14-054	SPRING WASHER	96
17-025	SPACER WASHER .008 & .047	8 pr.
17-031	GREASE BOLT	1
17-046	LUBE TUBE ASSEMBLY - 19" LONG	3
14-041	LUBE TUBE ASSEMBLY - 15" LONG	2
TT-1502	OILITE THRUST BEARING	40
TT-1503	OILITE THRUST BEARING	9
TT-1709-1	OILITE THRUST BEARING	3
23-008	COVER ASSEMBLY	1
23-013	CABINET ASSEMBLY	1
23-030	FEED GAGE ASSEMBLY	1
21-026	MOTOR 5 H.P.	1
21-030	STARTER	1
21-027	HEATER	3
20-026	PULLEY-MOTOR	1
17-053	PULLEY-DRIVEN	1
17-054	H x 1 - BUSHING	1
22-036	"V" BELT	2

PARTS LIST

FOR

FLAGLER HIGH SPEED QUADFORMER MACHINE

<u>NEW PART NO.</u>	<u>DESCRIPTION</u>	<u>AMOUNT REQ'D.</u>
21-060	TOP 1 - "S" CLEAT ROLL	1
21-061	TOP 2 - "S" CLEAT ROLL	1
21-062	TOP 3 - "S" CLEAT ROLL	1
21-063	TOP 4 - "S" CLEAT ROLL	1
21-064	TOP 5 - "S" CLEAT ROLL	1
21-065	TOP 6 - "S" CLEAT ROLL	1
21-066	TOP 7 - "S" CLEAT ROLL	1
21-067	TOP 8 - "S" CLEAT ROLL	1
21-068	TOP 9 - "S" CLEAT ROLL	1
21-069	TOP 10 - "S" CLEAT ROLL	1
21-070	BOTTOM 1 - "S" CLEAT ROLL	1
21-071	BOTTOM 2 - "S" CLEAT ROLL	1
21-072	BOTTOM 3 - "S" CLEAT ROLL	1
21-073	BOTTOM 4 - "S" CLEAT ROLL	1
21-074	BOTTOM 5 - "S" CLEAT ROLL	1
21-075	BOTTOM 6 - "S" CLEAT ROLL	1
21-076	BOTTOM 7 - "S" CLEAT ROLL	1
21-077	BOTTOM 8 - "S" CLEAT ROLL	1
21-078	BOTTOM 9 - "S" CLEAT ROLL	1
21-079	BOTTOM 10 - "S" CLEAT ROLL	1
21-200	TOP 1 - DRIVE CLEAT ROLL	1
21-201	TOP 2 - DRIVE CLEAT ROLL	1
21-202	TOP 3 - DRIVE CLEAT ROLL	1
21-203	TOP 4 - DRIVE CLEAT ROLL	1
21-204	TOP 5 - DRIVE CLEAT ROLL	1
21-205	TOP 6 - DRIVE CLEAT ROLL	1
21-206	TOP 7 - DRIVE CLEAT ROLL	1
21-207	TOP 8 - DRIVE CLEAT ROLL	1
21-208	TOP 9 - DRIVE CLEAT ROLL	1
21-209	TOP 10 - DRIVE CLEAT ROLL	1
21-210	BOTTOM 1 - DRIVE CLEAT ROLL	1
21-211	BOTTOM 2 - DRIVE CLEAT ROLL	1
21-212	BOTTOM 3 - DRIVE CLEAT ROLL	1
21-213	BOTTOM 4 - DRIVE CLEAT ROLL	1
21-214	BOTTOM 5 - DRIVE CLEAT ROLL	1
21-215	BOTTOM 6 - DRIVE CLEAT ROLL	1
21-216	BOTTOM 7 - DRIVE CLEAT ROLL	1
21-217	BOTTOM 8 - DRIVE CLEAT ROLL	1
21-218	BOTTOM 9 - DRIVE CLEAT ROLL	1
21-219	BOTTOM 10 - DRIVE CLEAT ROLL	1
21-222	ANTI-BOW SLIDE	1

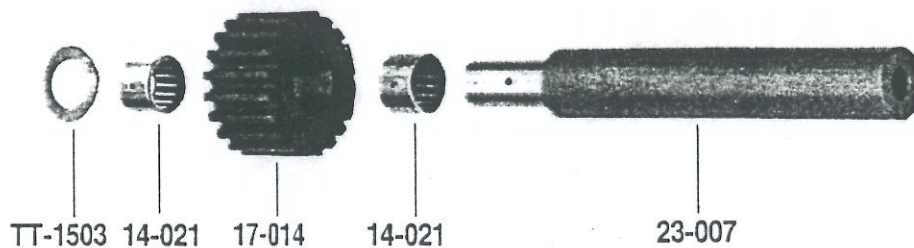
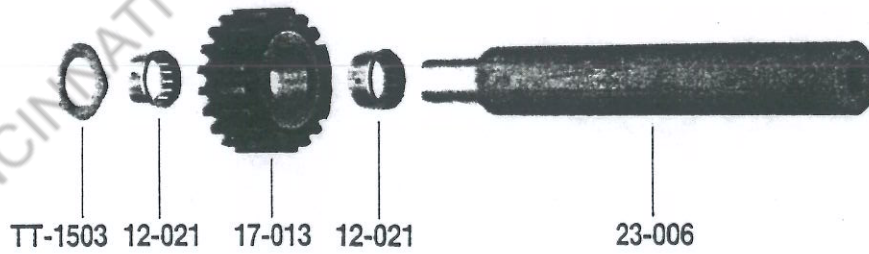
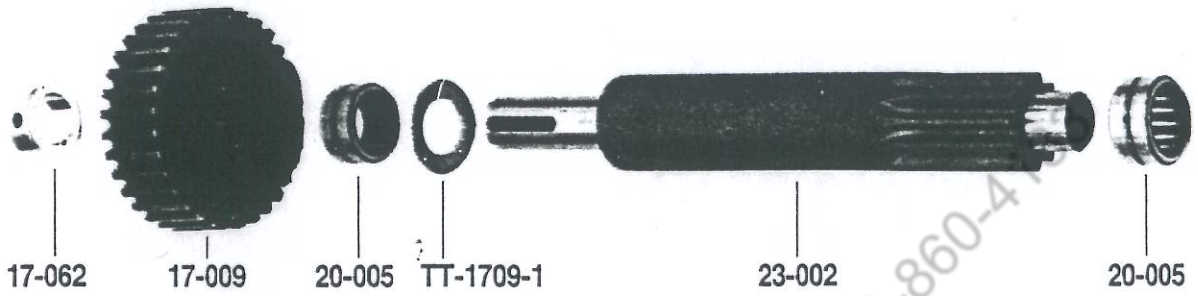
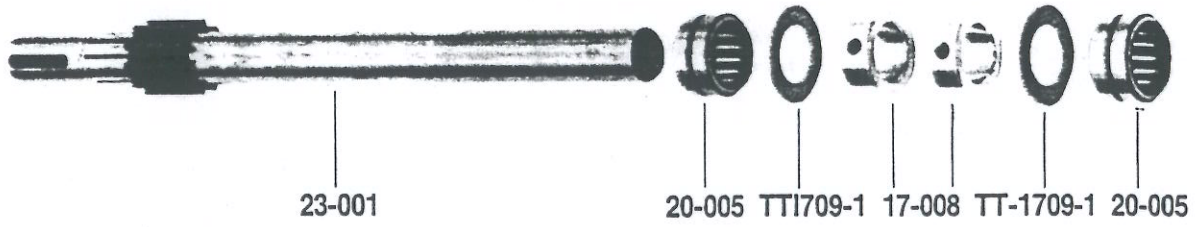

CINCINNATI PRECISION MACHINERY 513-860-4100

TEN STATION SPRING WASHER ASSY. INSTRUCTIONS

3/8 HOLD DOWN STUDS

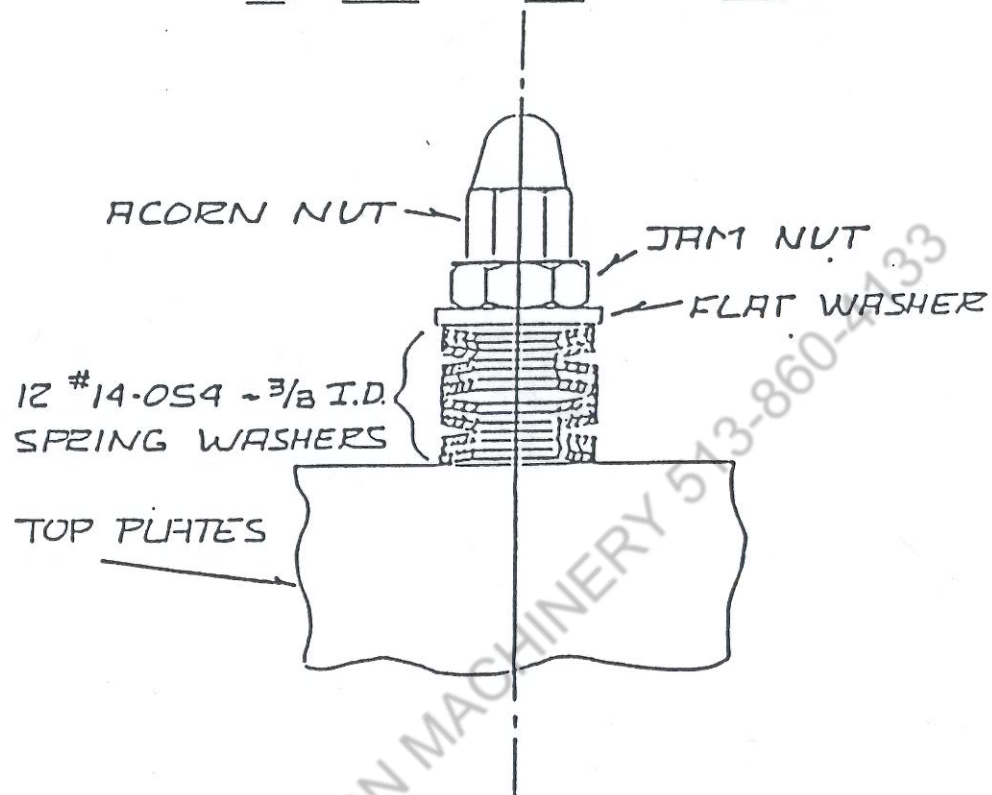

WHEN INSTALLING TIGHTEN JAM NUT UNTIL SPRING WASHERS ARE FLAT THEN BACK OFF ONE TURN AND TIGHTEN ACORN NUT.

TO WORK PROPERLY SPRING WASHERS MUST BE STACKED AS SHOWN.

**FLAGLER CORP.
56513 PRECISION DR.
CHESTERFIELD, MI 48051**

PHONE: 586-749-6300

FAX: 586-749-6363

SUGGESTED PROCEDURE FOR REMOVING
FORMING HEAD FROM CABINET

1. Remove the cover, top side plate and grease lines from the machine.
2. Remove the top head by removing the lock nuts and washers on the 3/8" hold down studs.
3. Move the feed gauges as to allow access to the 1/2" flat head screws, which hold the bottom head in the cabinet.
4. Support the weight of the bottom head before removing the 1/2" flat head screws.
5. Remove the 1/2" flat head screws, lower the bottom head, remove the belts from the pulley, tilt the head as to allow it to be raised up and out of the cabinet.
6. Lay the head on its side with the pulley side up. Remove the pulley, bull gear and the auxiliary rolls (if any) and all the 1/2" screws which will allow the removal of the top plate.
7. You will now be able to inspect for broken parts. See parts list and assembly print for ordering information. Please include serial number of machine when ordering parts.
8. For re-assembly, reverse the above procedure, making sure all of the keys are up and in line.