

REDRAWN 7/12/96 JS

REV: A ARG 02-19-03 TOLERANCE BLOCK
 ADDED.
 4990-3: ANGLE 1X5/8X1/8X5/8 WAS ANGLE
 1/8X1/2X3/4 LG

USE WELD FIXTURE 4990

TOLERANCES -UNLESS OTHERWISE SPECIFIED
 FRACTIONS +/- 1/32
 XX +/- 0.010
 XXX +/- 0.005
 ANGLES +/- 1/2°
 MACHINES SURFACE FINISH
 INSIDE RADII
 BREAK ALL SHARP CORNERS

4	2	4195		X	GUAGE PLATE
3	1	4990-3		X	ANGLE 1 X5/8 X 1/8X 5/8" LG.
2	1	4990-2		X	16 Ga. X 3 1/2 X 11 1/2" LG. CRS
1	1	4990-1		X	3/4 X 3/4 X 11 3/4" LG. CRS
ITEM	REQ'D.	SYMBOL	P	M	DESCRIPTION
		ENGEL INDUSTRIES ST. LOUIS, MISSOURI	DATE 10/26/76		GUAGE BAR ASS'Y. TRIPLES 800-B, 825, & 835 STORED ON DISK # 208
			SCALE 1=1		
			DRAWN McC		
			CHECKED		
				DWG. NO.	B-4990-A

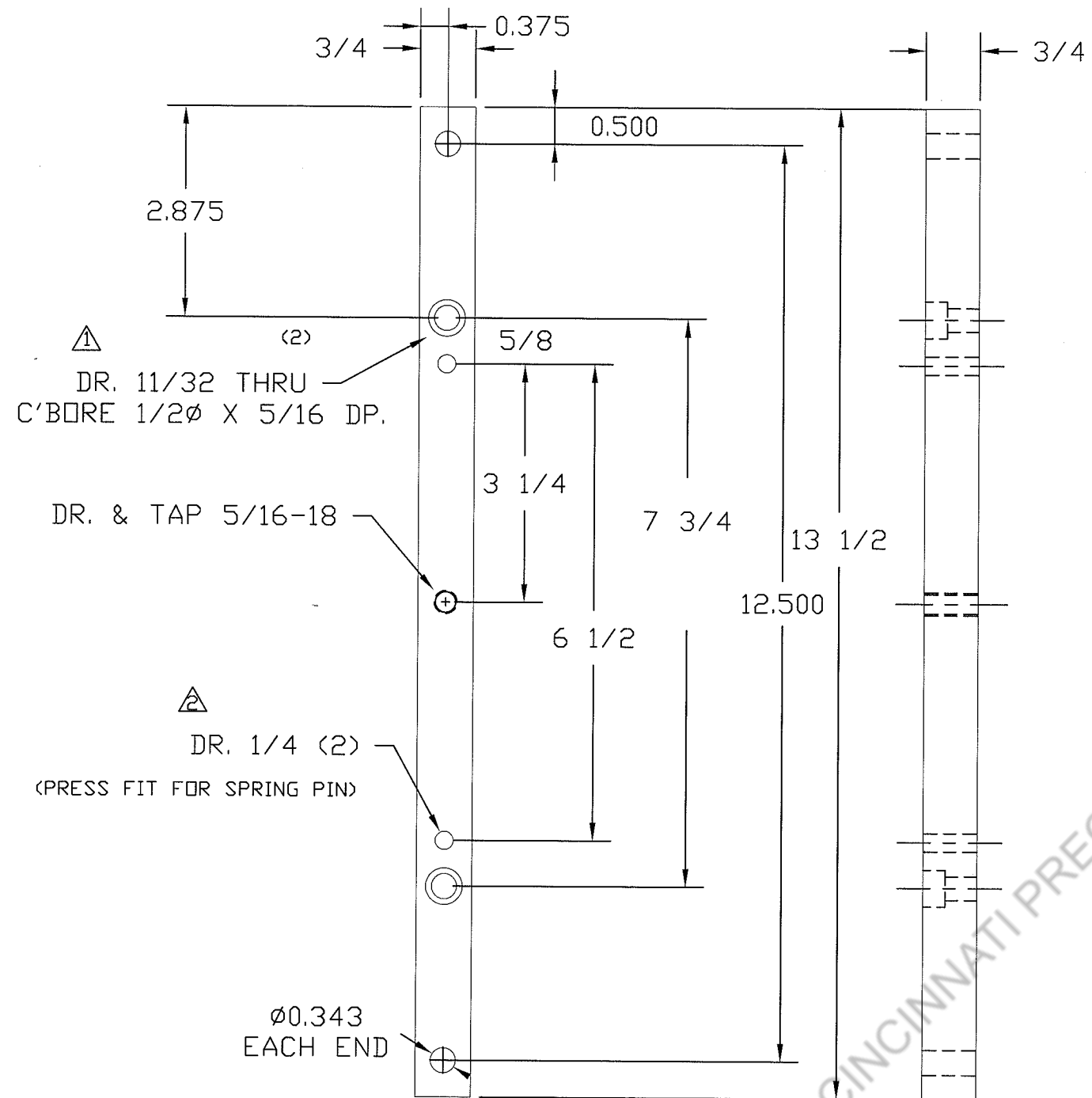

CINCINNATI PRECISION MACHINERY 513-860-4133

⚠️ ADDED 11/32 DIA HOLES 2 PALCES
 ⚠️ WAS .250 REAM 11/8/88 JS
 ⚠️ C'BORE ADDED 3/6/78

REDRAWN 7/30/93 JS

ITEM	REQ'D.	SYMBOL	P	M	DESCRIPTION
			X		CRS 3/4 X 3/4 X 13 1/2" LG.
		DATE	10/26/76		
		SCALE	1/2=1		
		DRAWN	McC		
		CHECKED			
ST. LOUIS, MISSOURI		STORED ON DISK #180		DWG. NO	A-4989