

Shopmaster

# ENGEL

## INDUSTRIES

ST. LOUIS, MISSOURI

### MAGNO-PAK PARTS LIST

(Prices valid as of 12-22-93)

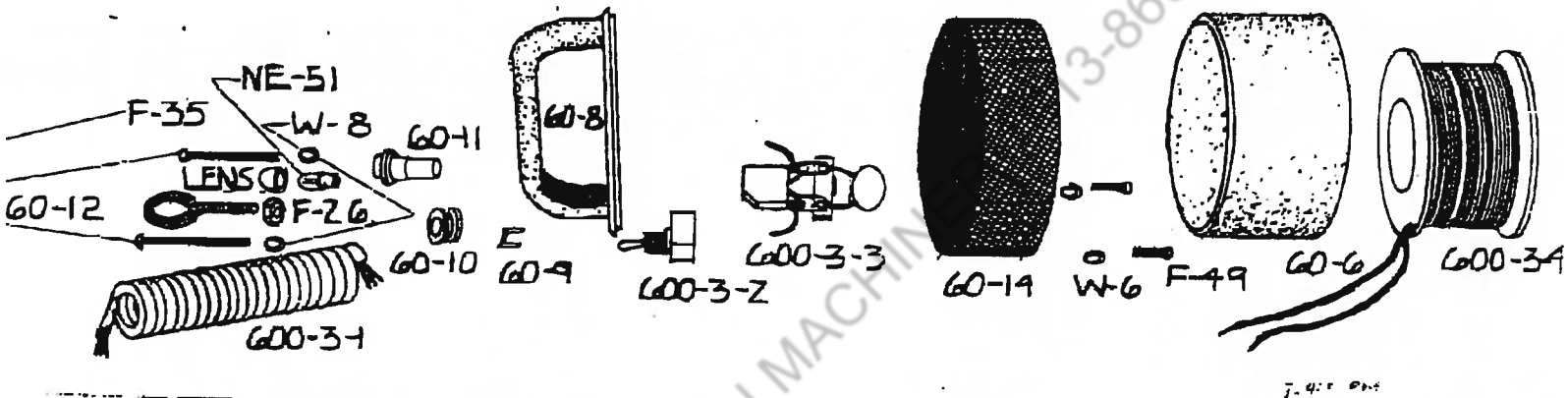

PART NO.	QTY. PER UNIT	EP NO.	DESCRIPTION
60-6	1	#1594	BOBBIN HOUSING \$.
60-8	1	#1596	HANDLE <del>79.48</del>
60-9	1		CORD RETAINING CLAMP
60-10	1	#572123	RUBBER GROMMET INSULATOR 59¢
60-11	1	#52001	PILOT LIGHT HOUSING <del>W/LENS</del> \$11.88
60-12	1		HOOK
60-14	1	#1602	PERFORATED METAL SHIELD \$19.49
600-3-1	1	M-RC	RETRACTABLE POWER CORD \$30.55
600-3-2	1	#551024	SWITCH(D.P.S.T.) \$9.52
600-3-3	1	#553004	SELENIUM RECTIFIER \$31.05
600-3-4	1	#553040	VARISISTOR \$17.46
NE-51	1	#1068846	BOBBIN W/MAGNET CORD \$189.66
F-26	1	#520032	NEON LAMP \$4.75
F-35	2		NUT 1/4-20
F-49	2		1/4-20 RD. HD. SCREW X 2-1/2' LG.
W-8	2		1/4-20 RD. HD. SCREW X 3/4' LG.
W-6	2		1/4' LOCK WASHER
			1/4' SPRING LOCK WASHER
			#531235 CINCH CONNECTOR \$1.13
			LENS #520009

COMPLETE MAGNO-PAK UNIT #76505 #1.13

\* REPLACED BY #553004 & 553040 & 531235



## CUTTER PART NUMBERS

Qty. Per Cutter	Part No.	Description
2	40-1	Cutter Wheel Part#542014 S7.75 FA.
1	40-2	Adjuster Bushing
1	40-3-1	Key 1/2x1/4 long
2	40-3-2	Key 1/2x5/8 long
1	40-4-1	Cutter Bolt 2-1/16 long (upper)
1	40-4-2	Cutter Bolt 3/8 long (lower)
3	40-5-1	Eccentric Bolt 15/16 long (side bearing)
2	40-5-2	Eccentric Bolt 1 1/8 long (track bearing)
2	40-6	Oiler
1	40-7	Cutter Casting
1	40-8	Plug (disk)
1	40-9	Chain (54 links)
1	40-10	Chain (62 links)
2	40-11	Offset Connecting Link
2	40-12	Master Connecting Link
1	40-13	1/2 Pipe 2 1/8 long (spacer)
1	40-14	Cutter Handle
1	40-15	Drive Shaft
1	40-16-1	Shaft 3-9/16 long
1	40-16-2	Shaft 3-15/16 long
1	40-17	Guard Cover for 20 Ga. Cutter
1	40-18	Guard Cover for 18 Ga. Cutter
2	40-19	Collar

End Switch - Part#55/058 - \$184.75 each

## ASSEMBLIES

1	400-1	Cutter (complete)
1	400-2	Hole location for "Coiled Kord" Mounting Bracket
1	400-3	Back Plate (welded assembly)
1	400-4	Back Chain Guard
1	400-5	Front Chain Guard
1	400-6	Belt Guard for 20 Ga. Cutter
1	400-7	Belt Guard for 18 Ga. Cutter

## PULLEYS

1	P-1	Adjustable Pulley
1	P-2	Plain Pulley

## BELTS

1	V-1	"V" Belt (for 20 Ga. Cutter)
1	V-2	"V" Belt (for 18 Ga. Cutter)

(Continued on Next Page)

## Cutter Parts and Part Numbers (Continued from preceding page)

## FASTENERS

Qty. Per Cutter	Part No.	Description
5	F-1	3/8 Hex Nut
2	F-2	1/2 Hex Nut
2	F-3	3/8x1 Allen Skt. Hd. Cap Screw (track bearing mtg.)
7	F-5	1/4 Hex Nut
1	F-6	1/4x3 Rd. Hd. Stove Bolt (back plate adjuster)
1	F-7	5/16x5/16 Dg. Pt. Allen Set Screw (worm)
1	F-9	3/8x1 1/2 Allen Skt. Hd. Cap Screw (upper adj.)
1	F-10	3/8x1 1/4 Allen Skt. Hd. Cap Screw (lower adj.)
1	F-25	1/4 Square Nut
4	F-31	1/2x3/8 Rollpin
4	F-32	1/2" Retaining Rings
2	F-33	1/4x1/2 Hex Hd. Cap Screw
1	F-34	5/16x3/8 Allen Set Screw (pulley)
2	F-35	1/4x2 1/2 Rd. Hd. Stove Bolt
3	F-36	1/4x1 1/2 Rd. Hd. Stove Bolt
2	F-37	1/4x1 Hex Hd. Cap Screw
2	F-38	1/4x3/4 Stud
4	F-39	1/2x#10 Sht. Mtl. Screw

## WASHERS

4	W-1	3/8 I.D. x 7/8 O.D. Plain Washer
2	W-2	5/16 I.D. x 3/4 O.D. Plain Washer
2	W-3	3/8 I.D. x 1 O.D. x .020 Shim
6	W-6	1/4 Lock Washer
3	W-7	3/8 I.D. x 5/8 O.D. x .064 thick

## BEARINGS

4	B-1	Track Bearing
3	B-2	Support Bearing
1	B-3	Drive Shaft End Bearing
1	B-4	Drive Shaft End Bearing with Grease Seal
4	B-5	1/2 O.D. x 3/8 I.D. Bronze Bushing
2	B-6	Cutter Wheel Bearings

## GEARS

1	G-1	Spur & Sprocket Comb.
1	G-2	Spur Gear
1	G-3	Bronze Worm Gear
1	G-4	Idler Sprocket
2	G-5	Cutter Wheel Sprocket
1	G-6	Worm

## SPRINGS

1	S-2	Spring
---	-----	--------

## MOTORS

1	M-1	1/2-hp 110 V. A.C. Single Phase, 60 Cycle, 1725 RPM
1	M-2	3/4-hp 110 V. A.C. Single Phase, 60 Cycle, 1725 RPM