

800 Series Parts List

Item #	Engel Part #	# Req'd.	Description
1	4443	1	Frame Weldment
2	4269	1	Spindle Housing Assembly
3	4167	2	Motor Mount Angle Assembly
4	4111	1	Infeed Table
5	4112	1	Outfeed Table
6	4142	2	Bottom Spindle Housing
7	4255-1	16	Top Bearing Cage
8	4271	2	Head Rail
9	513026	18	Post-Spindle Housing (4167-1)
10	4173	2	Spreader - Bottom Spindle Housing (825-835)
11	4173-3	2	Spreader - Bottom Spindle Housing (800)
12	4166-1	4	Spreader - Head Rail (825-835)
13	4166	4	Spreader - Head Rail (800)
14	4110	16	Spindle (825-835)
15	4401	16	Spindle (800)
16	4158-1	7	Idler Shaft (825-835)
17	4158-6	7	Idler Shaft (800)
18	4151	2	Mounting Plate - Speed Reducer 9825-835)
19	4151-2	2	Mounting Plate - Speed Reducer (800)
20	501031	1	Motor - 5 H.P.
21	512011	1	Sheave - BK-70
22	512014	1	Sheave - BK-62
23	562006	1	Belt - BK-42
24	4234-1	16	Spool Adjusting
25	511195	32	End Cap Washers (4219)
26	4165-1	7	Grease Bolts - 3/4" long
27	500002	16	Adjusting Bolts 3/8-24 x 3" long (800-825)
28	500001	16	Adjusting Bolts 3/8-24 x 2-1/2" long (835)
29	4211	8	Upper Spindle Gear (800-825)
30	4159	8	Upper Spindle Gear (835)
31	4211-H	16	Bottom Spindle Gear
32	4994-WB	7	Idler Gear 2-3/4 rd., bore 1-1/8" (800B)
	4994-1-WB	7	Idler Gear 2-3/4 rd., bore 1-1/2" (800U)
	4210-WB	7	Idler Gear 3-1/4 rd., bore 1-1/8" (800,825,835)
	4210-1-WB	7	Idler Gear 3-1/4 rd., bore 1-1/2" (800T,835)

800 Series Parts List

Item #	Engel Part #	# Req'd.	Description
1	4443	1	Frame Weldment
2	4269	1	Spindle Housing Assembly
3	4167	2	Motor Mount Angle Assembly
4	4111	1	Infeed Table
5	4112	1	Outfeed Table
6	4142	2	Bottom Spindle Housing
7	4255-1	16	Top Bearing Cage
8	4271	2	Head Rail
9	513026	18	Post-Spindle Housing (4167-1)
10	4173	2	Spreader - Bottom Spindle Housing (825-835)
11	4173-3	2	Spreader - Bottom Spindle Housing (800)
12	4166-1	4	Spreader - Head Rail (825-835)
13	4166	4	Spreader - Head Rail (800)
14	4110	16	Spindle (825-835)
15	4401	16	Spindle (800)
16	4158-1	7	Idler Shaft (825-835)
17	4158-6	7	Idler Shaft (800)
18	4151	2	Mounting Plate - Speed Reducer 9825-835)
19	4151-2	2	Mounting Plate - Speed Reducer (800)
20	501031	1	Motor - 5 H.P.
21	512011	1	Sheave - BK-70
22	512014	1	Sheave - BK-62
23	562006	1	Belt - BK-42
24	4234-1	16	Spool Adjusting
25	511195	32	End Cap Washers (4219)
26	4165-1	7	Grease Bolts - 3/4" long
27	500002	16	Adjusting Bolts 3/8-24 x 3" long (800-825)
28	500001	16	Adjusting Bolts 3/8-24 x 2-1/2" long (835)
29	4211	8	Upper Spindle Gear (800-825)
30	4159	8	Upper Spindle Gear (835)
31	4211-H	16	Bottom Spindle Gear
32	4994-WB	7	Idler Gear 2-3/4 rd., bore 1-1/8" (800B)
	4994-I-WB	7	Idler Gear 2-3/4 rd., bore 1-1/2" (800U)
	4210-WB	7	Idler Gear 3-1/4 rd., bore 1-1/8" (800,825,835)
	4210-1-WB	7	Idler Gear 3-1/4 rd., bore 1-1/2" (800T,835)

800 Series Parts List

33	511088	14	Bearing Needle - B-1416
34	511018	32	Bearing Needle - B-2016
35	511019	16	Inner Race - IR-162016
36	511076	16	Inner Race - IR-162020
37	511094	14	Thrust Bearing - TRA-1423
38	511078	32	Thrust Bearing Bronze Amplex
39	571033	32	Disc Springs - Z12 (.049)
39	571034	32	Disc Springs - Z12 (.059)
40	500019	18	Spring Pins - 3/16 x 1
41	4171	82	Woodruff Key - 3/16 x 1
42	4170	17	Woodruff Key - 1/4 x 1
43	HDW.	4	Hex Head Bolt - 1/2-20 x 1" long
44	500032	46	Hex Head Bolt - 3/8-24 x 1-1/4" long
45	500031	32	Hex Head Bolt - 3/8-24 x 1" long
46	500021	7	Hex Head Bolt - 3/8-24 x 3/4" long
47	HDW.	40	3/8 - 24 Hex Nuts
48	572104	14	Washers CI-1-FW Carr Lane

CINCINNATI PRECISION MACHINERY 513-535-4133

800 Series Parts List

Reducer Assembly

Item #	Engel Part #	# Req'd	Description
49	4241	2	Pinion Chassis Speed Reducer
50	4174	2	Mount Brackets
51	4182	1	No. 4 Pinion
52	4181	1	No. 3 Pinion
53	4180	1	No. 2 Pinion (835)
54	4179	1	Primary Drive (835)
55	4178	1	Primary Drive (800-825)
* 56	4220	1	Transfer Shaft Idler
* 57	4210	1	Idler Gear - G-28
58	4159-H	1	Spur Gear - G-27
59	4213	1	Spur Gear - G-26
60	4212	1	Spur Gear - G-25 (835)
61	4147	1	Spacer - Pinion - Primary Drive
62	4148	1	Spacer - No. 3 Pinion
63	4149	1	Spacer - No. 4 Pinion
64	511157	4	Bearing Needle - JH-1612-OH
* 65	511102-1	3	Bearing Needle - JH-1412-OH (800-825)
* 66	511102-1	5	Bearing Needle - JH-1412-OH (835)
67	511096	5	Thrust Race TRA-1625
* 68	511094	4	Thrust Race TRA-1423 (800-825)
* 69	511094	6	Thrust Race TRA-1423 (835)
70	573015	1	Snap Ring 1" (5100-98)
* 71	573002	2	Snap Ring 7/8" (5100-87)
72	HDW.	8	Hex Head Bolts - 1/2 - 20 x 1-1/2" long

* = 9850-A

Idler Shaft Ass'y Package
(use only as replacement if not
replaced on old style machine already.)

CINCINNATI PRECISION 513-860-4133

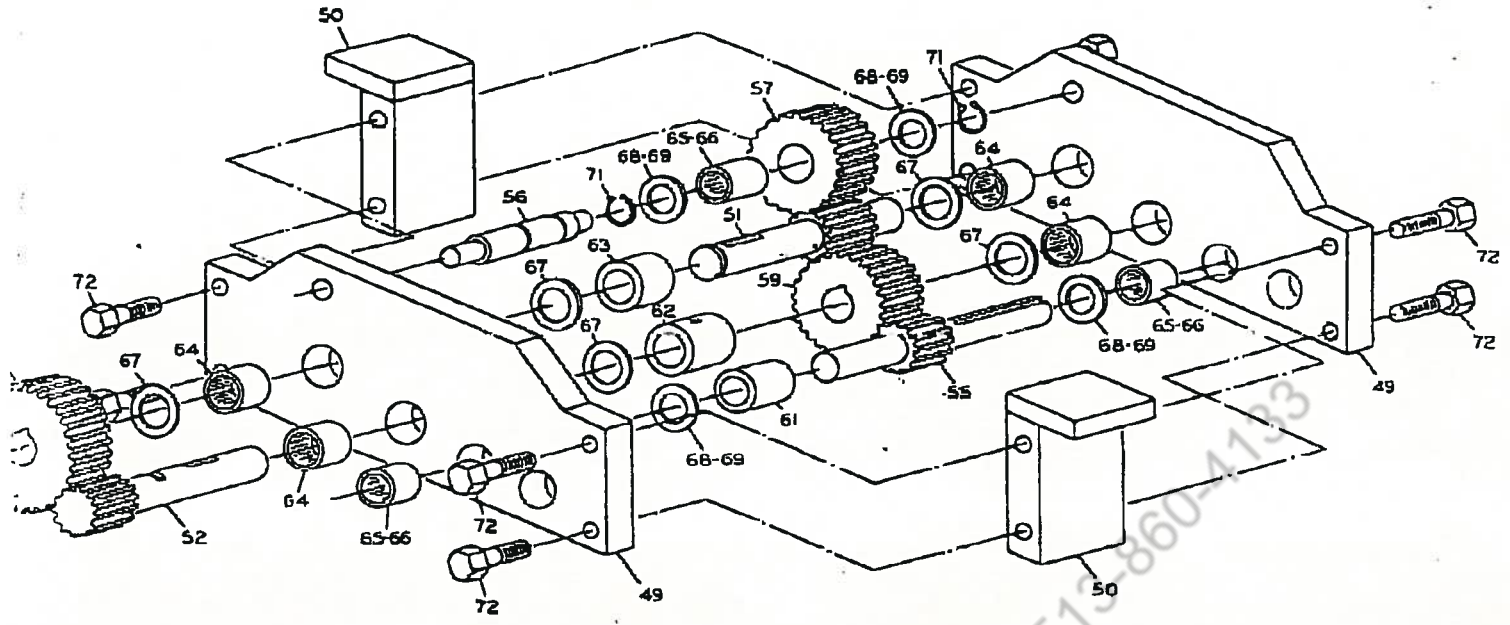

3 PINION REDUCER

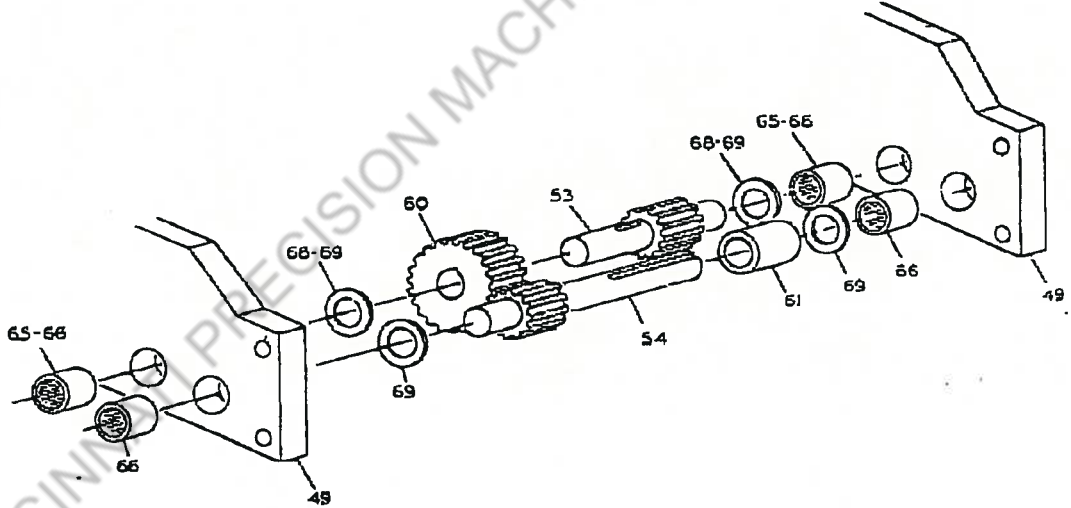

FIRST 2 PINIONS OF 4 PINION REDUCER

(2 OF 2)

ENGEL EQUIPMENT
INC.
ST. LOUIS MO.

800 - 825 - 835 ROLLFORMERS

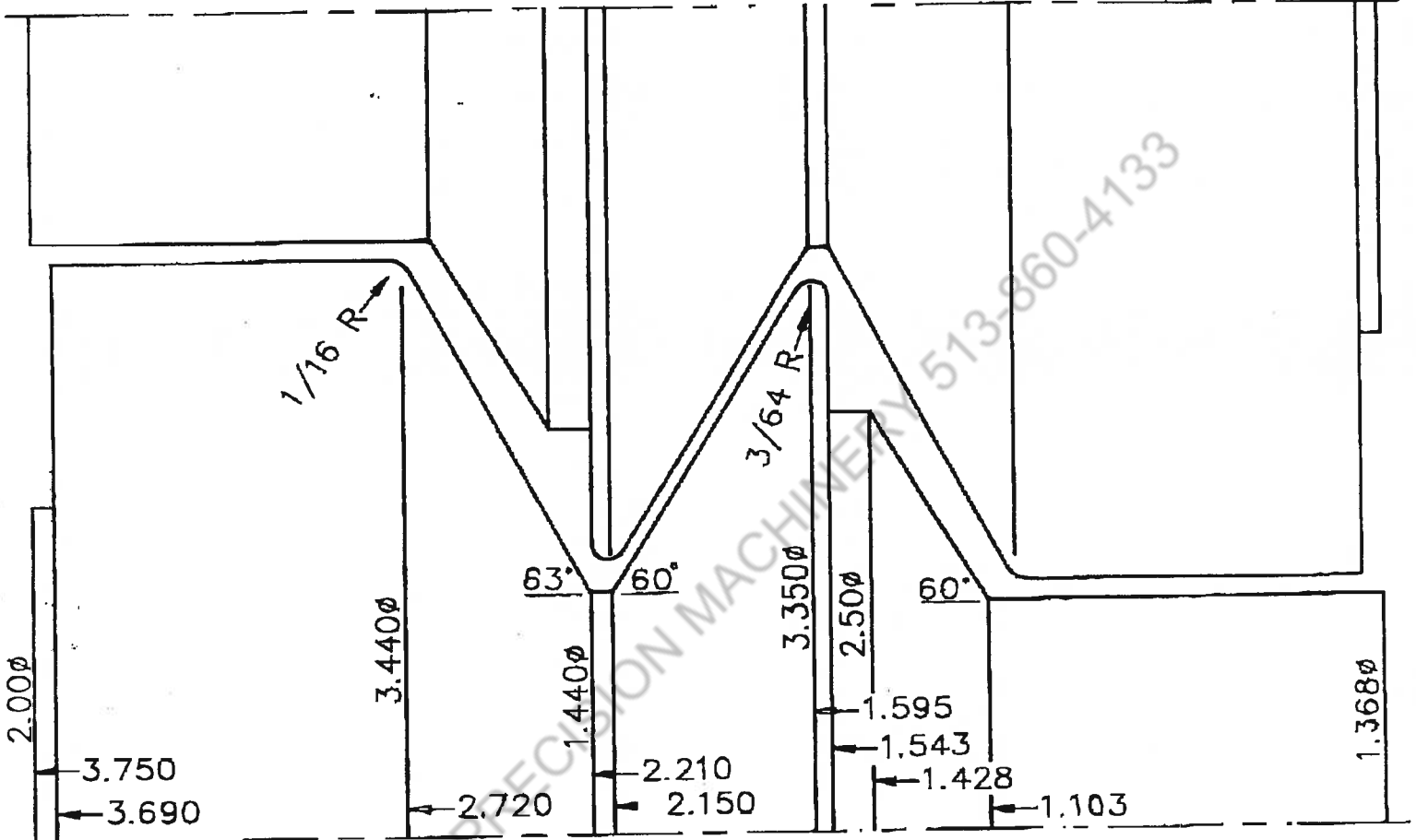

CINCINNATI PRECISION MACHINERY 513-860-4133

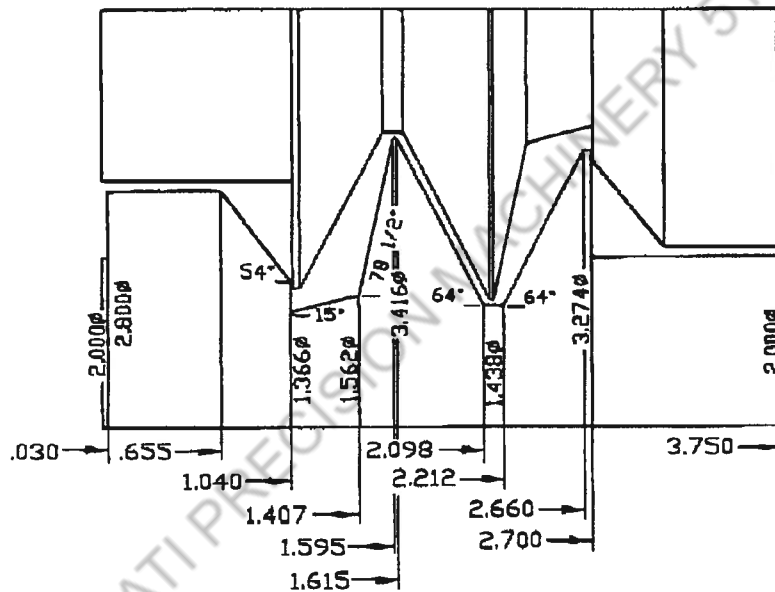

ITEM	REQ'D	PUR	MAKE	DESCRIPTION	
		DATE	7-27-92	FLAT 'S' SLIP 22 GA. 825 STAT.-5	
		SCALE	2X		
		DRAWN	McC	ASSY. NO.	DWG. NO. T5284
		CHECKED			

NEW STYLE



BORE: 1.000/1.001 3/16 X 3/32 K'WAY
 HEAT TREAT: .015/.020 DP, CARBO-NITRIDE
 BREAK ALL SHARP EDGES .010 R MAX.

REDRAWN 10/28/98

				X 3 5/8 ϕ X 3 7/8" LG. C1117L	
ITEM	REQ'D.	SYMBOL	P	M	DESCRIPTION
 ST. LOUIS, MISSOURI			DATE 11/4/63 SCALE 1=1 DRAWN JERRY CHECKED		'S' CLEAT ROLL STATION #5 22 GA. MATERIAL
			STORED ON DISK # 231		DWG. NO. T5071