

Engel Rollformer 800 Series

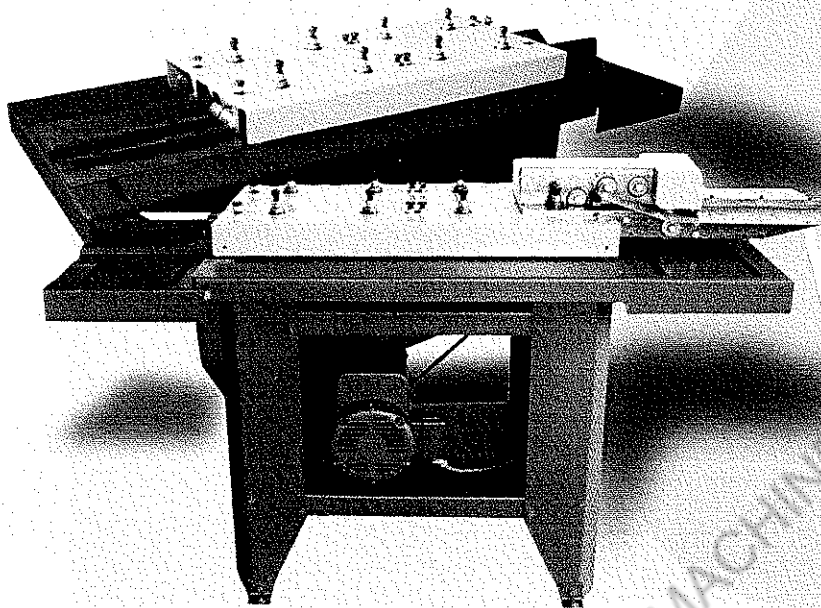

Features

- ~ Optional electricals available including single phase for job site applications.
- ~ No opening rolls required on any set of tooling.
- ~ All units have eight (8) forming stations with tooling mounted on turned, ground and polished 1" spindles.
- ~ Extra large bearings with inner races.
- ~ Standard with 5HP motor producing approximately 90 FPM pitchline speed.
- ~ Hardened steel in-feed guides to handle rough plasma cut edges.

~ Optional slitter attachments available for either "S" or drive cleats, or a combination slitter for both on the 825

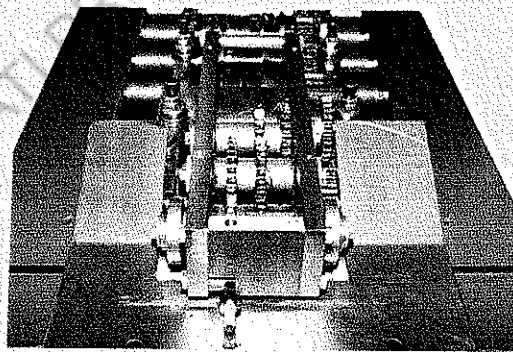

Tooling Profiles

- ~ Flat "S"
- ~ Drive Cleat
- ~ Male Button Lock
- ~ Female Button Lock
- ~ Drop Edge
- ~ Pittsburgh Lock
- ~ Double Seam (Acme)
- ~ Duplex
- ~ Triplex
- ~ 180° Hem
- ~ 45° Drip Edge with Hem

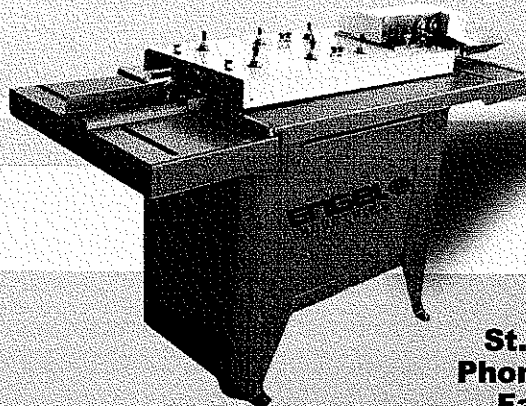

8122 Reilly Ave.
St. Louis, MO 63111
Phone (314) 638-0100
Fax (314) 638-4048
www.engelind.com

Roll Machine Instructions
Series 800 Roll Formers
Index

NOTICE

Some materials in this manual may not pertain to your specific machine.

- I Receiving Machine – p 1
 - 1 Unloading Procedure – p 1
 - 2 Positioning Machine – p 1
 - 3 Electrical Connections – p 2
 - 4 Lubrication – p 2
 - A Disconnection
 - B Roll Cover
 - C Gear Grease
 - D Light Oil
 - E Returning Power
 - F Units with Oil Bath Reducers
- II Roll Capacities and Material Requirements – p 2-3
- III Outboard Roll Sets – p 3
 - 1 Types
 - A Pittsburgh (18 Ga.) 1/2" pocket
 - B Pittsburgh (16 Ga.) 1/2" pocket
 - C Female Button Lock (20 Ga)
 - D Male Button Lock (20 Ga)
 - E Standing Seam – Duplex
 - F Right Angle Flange (16 Ga)
 - G Tap-In-Lock
 - H Standing Seam – Triplex
 - I Right Angle Flange (18 Ga)
 - J Duplex
 - K Right Angle

- 2. Adjustments – p.4
- IV. Roll Clearances – p.4
- V. Female Snap Lock #8 Top – p.5 (diagram – p.6)
 - 1. 20 Gauge Capacity
 - 2. 24 Gauge Capacity
- VI. Female Pittsburgh #7 Top – p.5 (diagram – p.6)
 - 1. 16 Gauge Capacity
 - 2. 18 Gauge Capacity
- VII. Female Button Lock – p.7
- VIII. Instructions for Changing Button Punches – p.8
- IX. Model 800P Adjustments – p.9
- X. Additional Adjustments – p.9
- XI. In-Feed Guide Settings – p.10
 - 1. Pittsburgh
 - 2. Triplex
 - 3. Male Button Lock
 - 4. Female Button Lock
 - 5. Drive Slip – Outboard
 - 6. Acme Lock
 - 7. Right Angle
- XII. T I L – p.11
- XIII. M-800 with MR-CEF-800 – p.11-12
- XIV. Warning – p.13
- XV. Diagrams – p.14-19
- XVI. Parts Lists – p.20-23

CHINNATI PRECISION MACHINERY 513-860-4133

IMPORTANT CAUTION FOR RUNNING "S" SLIPS

Roll-formers with "S" slip capabilities (ex. 800-S, 825) , can be easily damaged or jammed by feeding one part after another too quickly. The "S" slip slows down as it progresses through the roller dies. If a part is in the machine such that the tail end is not clear of station #6, the next part in can catch up and even overlap the previous part before it exits the machine. This will result in a potentially serious jammed condition. See instruction manual.

Jamming of this nature can cause the warranty to be voided.

CINCINNATI PRECISION MACHINERY 513-860-4133

ENGEL INDUSTRIES, INC.
ROLL MACHINE INSTRUCTIONS

Receiving Machine

- Visibly check machine for possible shipping damage
- When damage is evident, insist on the freight bill
- If repairs are necessary, contact Engel Industries, Inc

Unloading Procedure

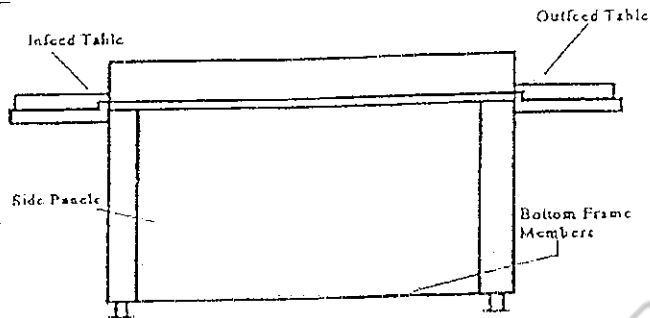

- When it is necessary to lift the machine off the transport vehicle and lower it to the ground, lift or support the machine by using the skids or by lifting the machine by the bottom frame members. (NOTE: Lifting the machine by the in-feed or out-feed table would result in extensive damage to the machine.) If the machine is unloaded onto a loading dock, then rollers can be put under the skids, or the machine can be slid or dragged on the skids

Positioning Machine

- Move the machine to its desired location
- Remove the skids.
- Level machine before operation (leveling feet are provided) Once leveled, lock the jam nut at each corner or leg of the machine

Electrical Connections

Supply electrical service to the starter box (located under the in-feed table) in accordance with local electrical supply codes. Refer to the connecting instructions on the inside of the starter box. (NOTE: If the machine is powered by a three (3) phase motor, it is possible to initially wire the motor in reverse. If this happens, switch two (2) of the three (3) supply wires. This will correct the rotation of the motor.)

Lubrication

After approximately every 80-100 hours of use, or every two (2) weeks, lubricate the machine in the following manner:

1. As a safety precaution, disconnect electrical supply
2. Remove top roll cover (guard).
3. Apply open-type gear grease to the exposed surfaces of all the gears

Recommended: Chem-a-lube (made by National Chemsearch Corp., in Dallas, St. Louis, New York, Los Angeles and Montreal) or equivalent

4. Apply light oil to the forming rolls to prevent galvanized build-up as required. (Applying oil to both sides of a strip of metal and passing it through all the rolls is an excellent way to lube the rolls when heavy use occurs.)
5. Connect power, turn machine on and with a pressure type grease gun, apply grease to lube fittings. (NOTE: Remove right apron for access to fittings on side plate for idler gears.) Grease fittings are located on the gear reduce under the machine also.
6. For units with oil bath reducers, change oil at least once a year

Recommended: Lubriplate #8 (made by Fiske Bros. Refining Co., in Toledo and Newark) or equivalent

IMPORTANT: Do not use hypoid grease, as it will cause extensive damage to reducer gears

Models Roll Capacities and Material Requirements

Shape	Material Required	Capacity
Pittsburgh Lock	15/16"	20-28 Gauge
Female Button Lock (20 Ga.)	1 3/8"	20-24 Gauge
Female Button Lock (24 Ga.)	1 1/8"	24-26 Gauge

Model 800-825
Roll Capacities and Material Requirements

Shape	Material Required	Capacity
Pittsburgh Lock	15/16"	20-28 Gauge
Female Button Lock (20 Ga)	1 3/8"	20-24 Gauge
Female Button Lock (24 Ga)	1 1/8"	24-26 Gauge
Male Button Lock (20 Ga)	7/16"	20-26 Gauge
Male Button Lock (24 Ga.)	7/16"	24-26 Gauge
Acme (Double Seam)	7/16"	20-28 Gauge
Drive Cleat	2 1/8"	20-28 Gauge
Reinforced Flat "S"	3 3/4"	22-28 Gauge
Tap-In-Lock	1 3/4"	22-28 Gauge
Standing Seam	1 1/8"	22-28 Gauge
Right Angle Flange	9/16"	20-28 Gauge

Models 835, 1000, S-5-10, 1240, 1535 and 1640
Outboard Roll Sets

Shape	Materials Required	Capacity
Pittsburgh (18 Ga) 1/2" Pocket	1 1/4" -notch 1 1/8"	18-24 Gauge
Pittsburgh (16 Ga) 1/2" Pocket	1 1/2" -notch 1 3/8"	16-20 Gauge
Female Button Lock (20 Ga)	1 3/8"	20-24 Gauge
Male Button Lock (20 Ga)	7/16"	20-24 Gauge
Standing Seam—Duplex	2 1/8"	16-20 Gauge
Right Angle Flange (16 Ga)	1"	16-20 Gauge
Tap-In-Lock	3 1/2"	18-24 Gauge
Standing Seam—Triplex	2 1/8"	18-24 Gauge
Right Angle Flange (18 Ga)	1"	18-24 Gauge
Duplex	1 5/8"	16-20 Gauge
Right Angle	1 1/2"	16-20 Gauge

Adjustments

This machine is factory adjusted, however, after much usage adjustments may be necessary

Roll Clearance
Models 825, 835, 1030, 1240 and 1535

The gaps or clearances between the top and bottom outboard roller dies should be approximately .010 on all roll sets, with the exception of the 16 Gauge Duplex and Pittsburgh roll sets which are set at .036 Also 18 Gauge Triplex roll sets, which are set at .025 and 18 Gauge Pittsburgh roll sets which are set at .015 The adjusting nuts must be locked Then check to see that the clearances are as stated above.

Roll Clearance Standard Tooling
 (right or left outboard installation)

Pittsburgh - 16 Gauge .035	Triplex- 18 Gauge .025	Right- 16 Gauge .035
18 Gauge .015	22 Gauge .015	Angle 18 Gauge .015
20 Gauge .010		20 Gauge .010
Male- 18 Gauge .025	Acme- 18 Gauge .010	Female- 18 Gauge .025
Button 20 Gauge .010	Lock 20 Gauge .010	Button 20 Gauge .010
Lock 24 Gauge .010		Lock 24 Gauge .010
	Drive- 18 Gauge .015	
	Slip 20 Gauge .010	

Drive Cleat-20 Gauge

Outboard #1 .010
#4 .015
#5 .015
#8 .035

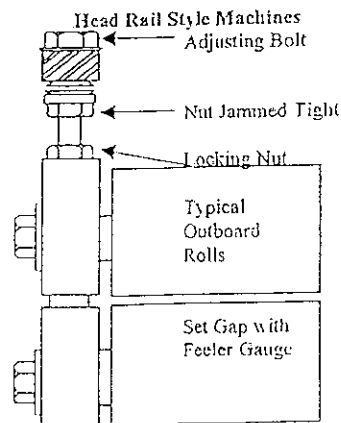
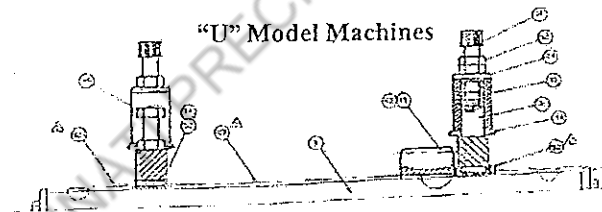

Female Snap-Lock #8 Top

20 Gauge Capacity:

- 1 Use deep groove for 20 and 22 Gauge
- 2 Use shallow groove for 24 and lighter

24 Gauge Capacity:

1. Use deep groove for 24 Gauge
- 2 Use shallow groove for 26 and lighter

Female Pittsburgh #7 Top

16 Gauge Capacity:

1. Free Standing unit 16 to 20 Gauge Capacity only
2. 16 Gauge rolls on transfer system (18 Gauge Capacity)
- 3 Use deep groove for 18, 20 and 22 Gauge
- 4 Use shallow groove for 24 and lighter.

18 Gauge Capacity:

- 1 Use deep groove for 18 and 20 Gauge.
- 2 Use shallow groove for 22 and lighter.

NOTE: This means the desired roll groove would be next to the end cap and bolt

CINCINNATI PRECISION MACHINERY 513-860-4133

Female Snap-Lock
20 and 24 Gauge
#8 Top

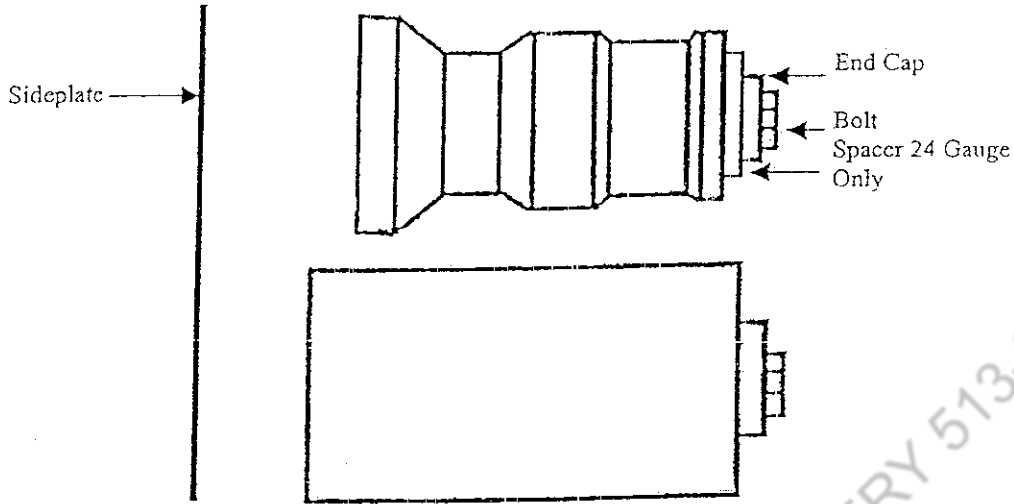

Pittsburgh
16 and 18 Gauge
#7 Top

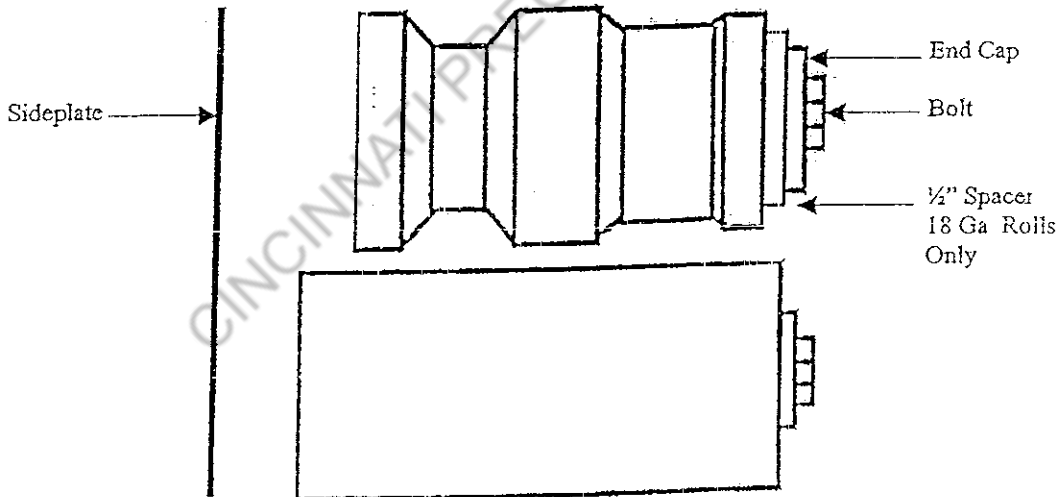

Female Button Lock

Used for 20 & 22 Ga

Used for 24 Ga and Lighter

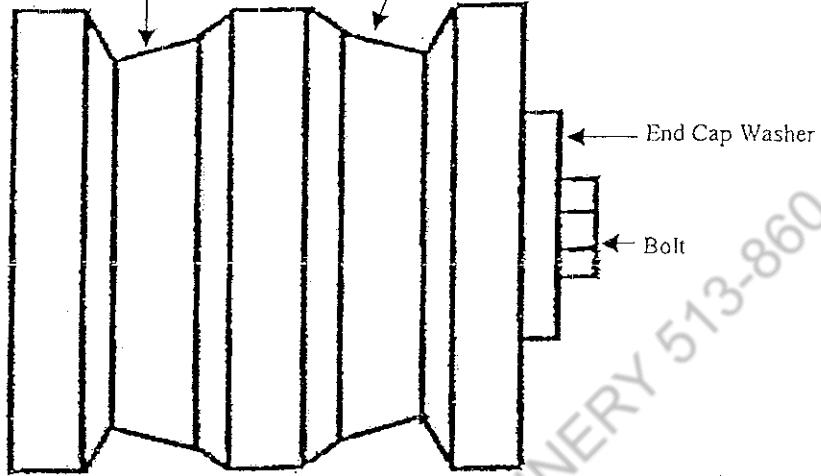

Inboard Side

Outboard Side

CINCINNATI PRECISION MACHINERY 513-860-4133

Instructions for changing Button Punches on Engel Snap-Lock Machine

- 1 Remove four (4) socket head screws holding head assembly to frame, and slide head back three (3) inches or so. On free standing unit, remove tie plate only.
- 2 Remove No. 2 bottom roll by removing hex head bolt and end cap washer. Slide Roll off of spindle.
- 3 On the backside of the roll there will be four (4) large socket head bolts, and four (4) small socket head set screws.
 - A Remove four (4) large bolts, and separate the two (2) parts of the roll.
 - B Loosen four (4) small socket set screws.
 - C Remove the four (4) punches, and replace with new ones.
 - D It may be necessary to lightly sand the sides of the new punches before they will fit in the slots.
 - E Be sure buttons are all the way to the back side of slot. If necessary, after putting roll back together, tap on the punches lightly with a brass hammer to seat to the proper depth.
 - F Tighten four (4) large bolts as tight as possible.
 - G Now tighten four (4) small socket set screws and replace roll on spindle, replace end cap and bolt.
 - H Slide head back into position and replace the four (4) bolts holding it into the frame. This applies to transfer system only.
- 4 Upper Slitting Wheel simply by removing end cap and bolt and removing the slitting half or upper roll.

WARNING: DO NOT LOOSEN BOLTS ON THE HEAD OF ANY FREE STANDING UNIT.

CAUTION: IF PRECISION (THIN) SHIMS ARE PRESENT BEHIND THE TOP OR BOTTOM ROLLS, BE SURE TO MAINTAIN THEIR POSITION WHEN RE-ASSEMBLING TAKES PLACE.

IF ALIGNMENT IS NOT MAINTAINED, THE KNIVES AND KNIFE ROLL CAN BE DESTROYED.

IT IS RECOMMENDED TO TURN THE MOTOR BELT BY HAND TO OBSERVE ANY POSSIBLE INTERFERENCE BETWEEN THE KNIVES AND KNIFE ROLL. NOTE: POWER MUST BE DISCONNECTED AND LOCKED OUT FOR SAFETY!!!

Model 800P Adjustments

To Set Roll Gap:

Loosen jam nut and set to clearance specified by turning adjusting screws until feeler gauge setting is obtained. Tighten the jam nut adjusting.

Spring tension is factory set. Should further changes be needed, more tension can be obtained by removing nut of tension screw and internal shims. It is recommended that you contact the factory for advice before doing so.

Additional Adjustments Model 800B-18

The procedure to adjust the helper on the 2.5 station area is as follows. This applies to going from heavy to light gauge material.

By using the square head set screw protruding through the safety hood, turn adjustment out (to the right) for heavy material and in (to the left for light material).

CINCINNATI PRECISION MACHINERY 513-860-4133

In-feed Guide Settings

Pittsburgh

20 Gauge 2 1/8" with offset
18 Gauge 2 5/16" with offset
16 Gauge 2 3/8" with offset

Measurements shown are good starting positions, other settings maybe necessary by adding more or less material moving guide (in-feed) (+ or -)

Triplex

Set in-feed guide to 1 1/2". If it will be necessary to lengthen material, take up by moving guide as needed

Male Button Lock

20 Gauge 1 1/32" (+ or -)
18 Gauge 1 1/32" (+ or -)

Drive cleat is center part in tooling.

Female Button Lock

24 Gauge 2 5/16" (+ or -)
20 Gauge 2 5/16" (+ or -)
18 Gauge 2 3/8" (+ or -)

Drive Slip - Outboard

20 Gauge 1 1/8" (+ or -)
16 Gauge 1 1/2" (+ or -)

Acme Lock

20 Gauge 1" (+ or -)
18 Gauge 1 5/8" (+ or -)
16 Gauge 1 3/8" (+ or -)

Right Angle

20 Gauge 1 5/16" (+ or -)
18 Gauge 1" (+ or -)

I.I.L.

22 Gauge: 6^T .015 7^T .030 8^T .045
 6^B .015 7^B .030 8^B .045

It may be necessary to add additional .020 to 6^B in order to get 90° on right angle

Male Button Lock

20-24-18 Gauge Capacity

8^T .030 8^B .030

Sometimes it will be necessary to shim #2^B as needed to get button punches at proper depth

I.I.L.

18 and 16 Gauge (S-5-10/W)

8^T .015 9^T .030 10^T .045
8^B .015 8^B .030 10^B .045
+.020 #9^B to get 90° on right angle

Duplex

16 and 18 Gauge (1640U)

10^T .015 11^T .030 12^T .045
10^B .015 11^B .030 12^B .045

Female Button Lock

20, 24 and 18 Gauge

(2^T) It maybe necessary to shim 2^T to better 90° bend on the hem position See drawing T5036
If lighter Gauges buckle in the length of the part or last turn over hem runs out, shim #4^T out to meet #4^B
See drawing T5039

M-800 with MR-CEF-800 (Drive Edge Only)

Roll Setting and Head Adjustment (Tension)

- 1 Set roll clearance .010 at station #1
- 2 Adjust head tension - 4 flats at #1
- 3 3 flats at stations #4, #5 and #8 - .015 roll clearance at these stations
- 4 Recheck roll clearance
- 5 Set in-feed guide 13/16" off outside
- 6 Flat of tooling
NOTE: It maybe necessary to set in-feed guide 1/32" offset at front of machine to keep material from leaving in-feed guide
- 7 Side roll setting - #2, #3, #4 and #5
.025 on bottom
.010 on side
- 8 Station #6 and #7
.010 on bottom
.045 on side

To Adjust Head Tension

- 1 Loosen Top jam nut (located on socket head bolt)
- 2 Tighten bottom jam nut down flat
- 3 Loosen (back off) flats indicated in instructions at station locations

CINCINNATI PRECISION MACHINERY 513-860-4133

WARNING

Never put your hands in the point of operation of any mechanical or electrical device.

If a machine is jammed, needs adjustments, needs die change, etc., always do a lock-out/tag-out procedure which means the power must be off and locked-out and any rams or beams will be blocked to ensure safety. This is a federal OSHA requirement and must be a written and training type of program.

CINCINNATI PRECISION MACHINERY 513-860-4133

3 Phase Pre-wired Starter
Dwg. EL-760-A

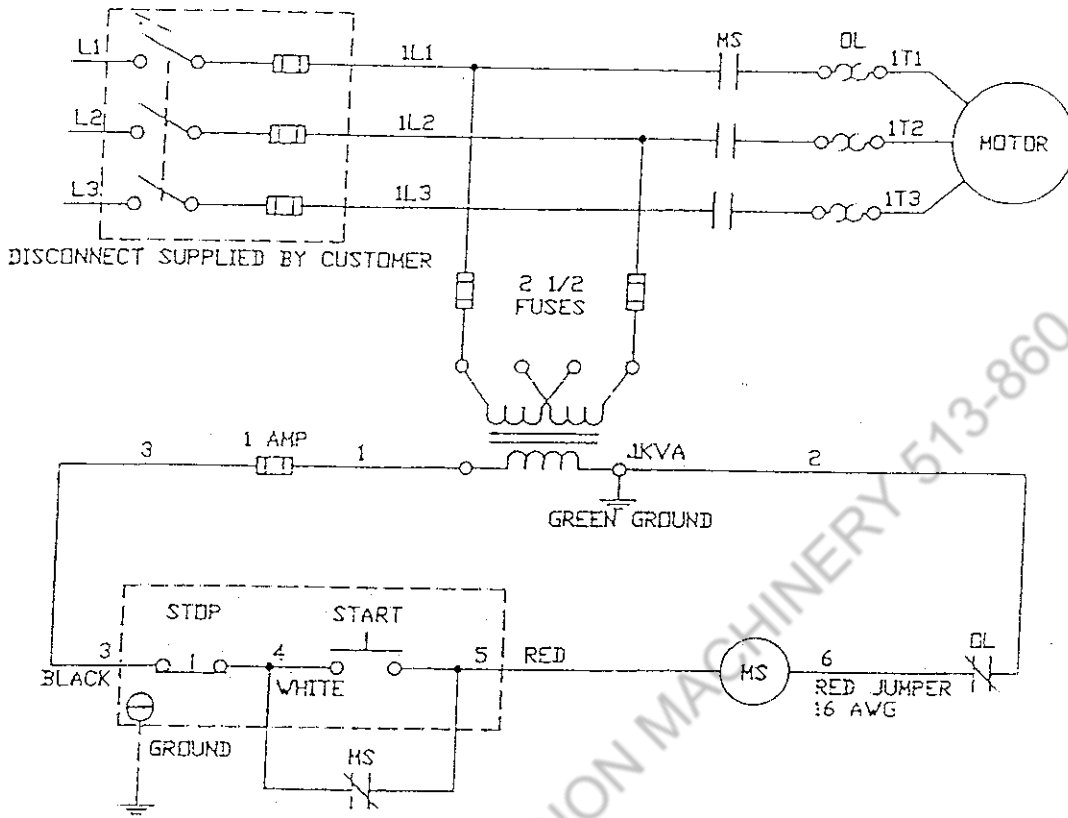

PENDANT CORD IS 16/4

CINCINNATI PRECISION MACHINERY 513-860-4133

Button Lock Female
 20 Ga 825 Stat.-2
 Dwg No T5036

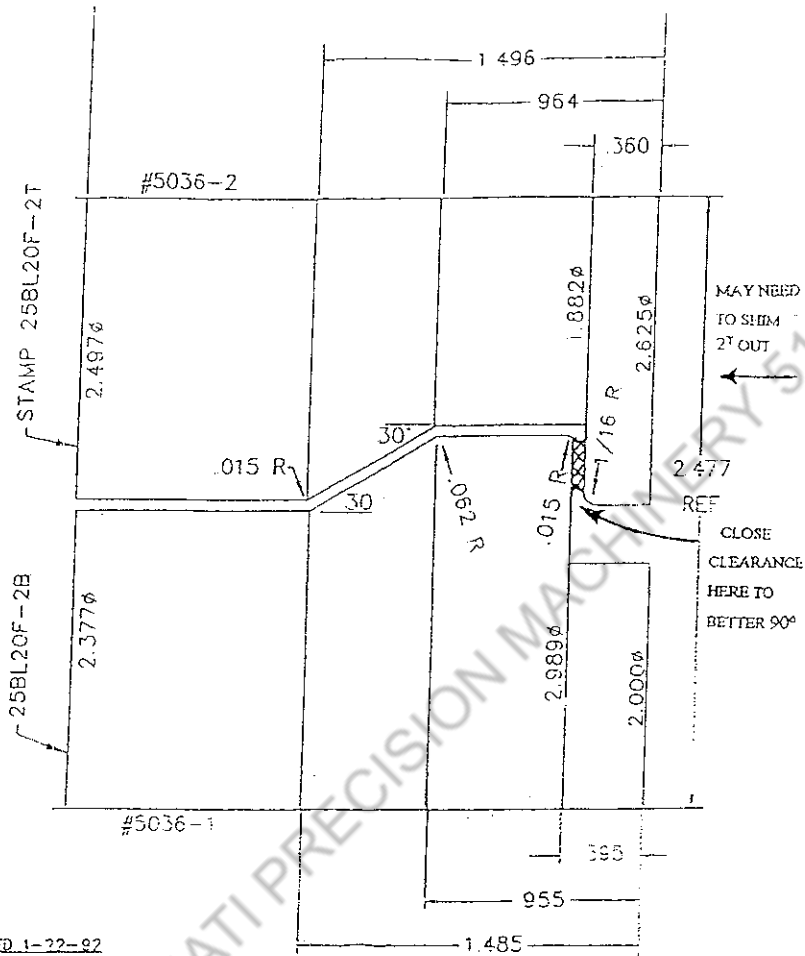

SCANNED 1-22-82

4. HEAT TREAT-CARBON-NITRIDE .020-.025 DEEP
3. BREAK ALL SHARP EDGES .03 R MAX
2. BORE 1.000-1.001 KEENAY 3/16
1. VERTICAL CENTERS ON SPRING LOADED MACHINES ARE 2.447.

Typical In-feed Guide
Setting Instructions

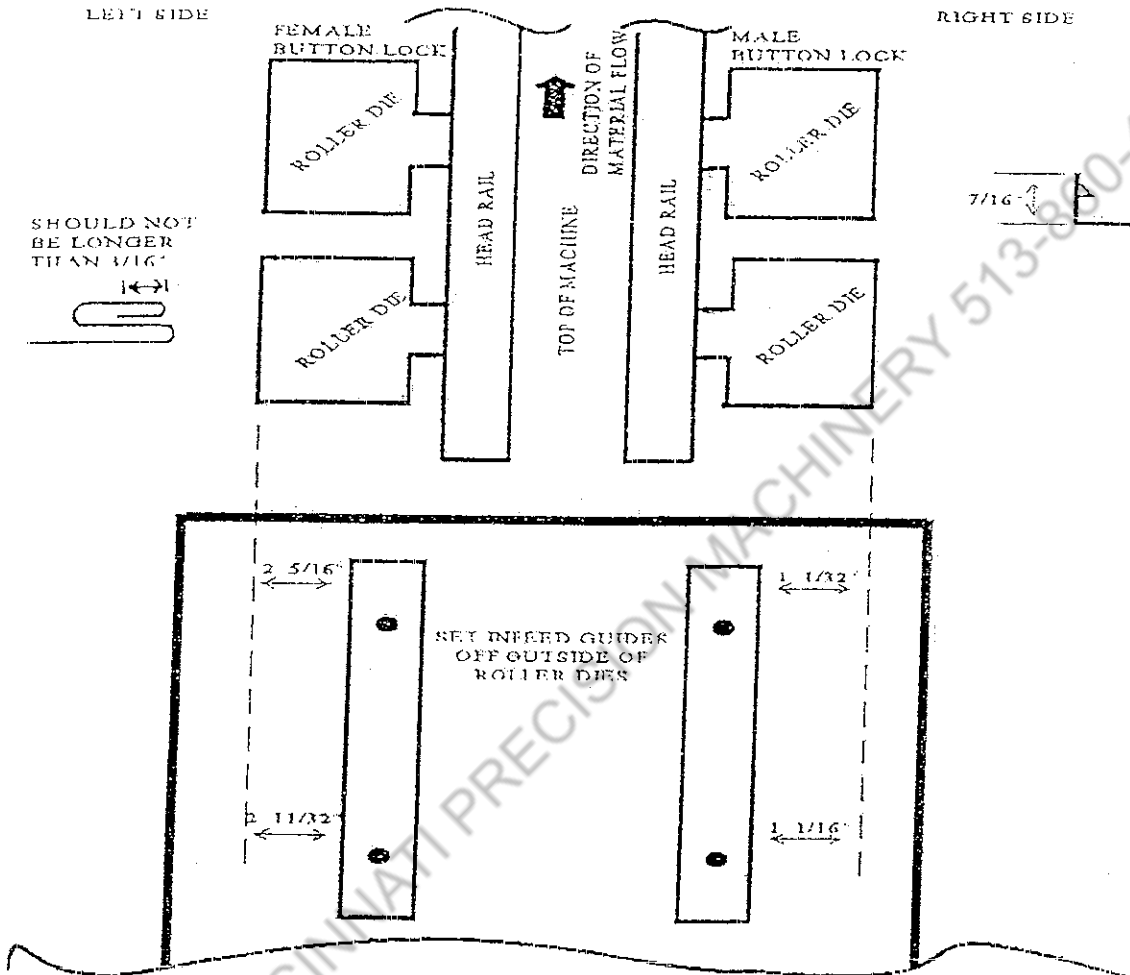

MR-CEF800
Station 1



MR-CEF800
 Station #6, #7
 Side Roll Setting

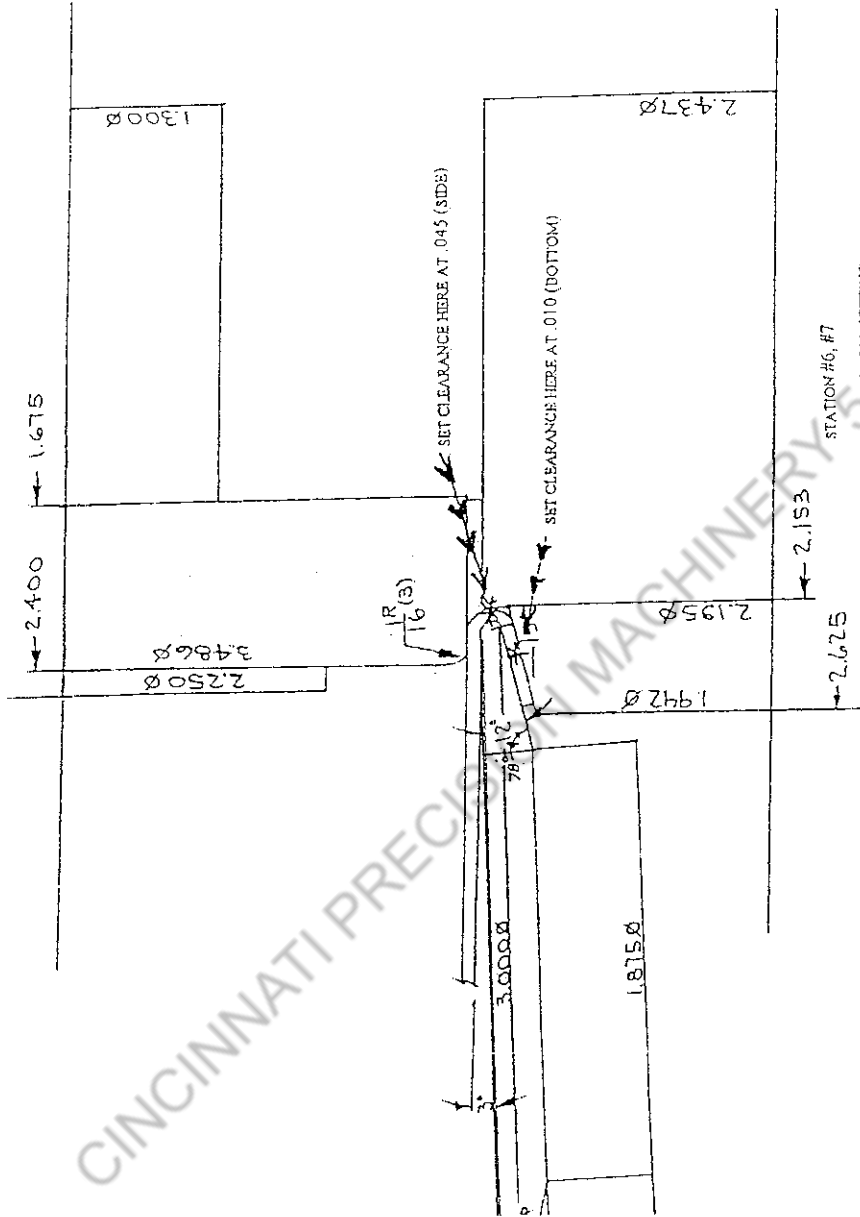

CINCINNATI PRECISION MACHINERY 513-860-4133

MR-CEF800
 Station #2, #3, #4 #5
 Side Roll Setting

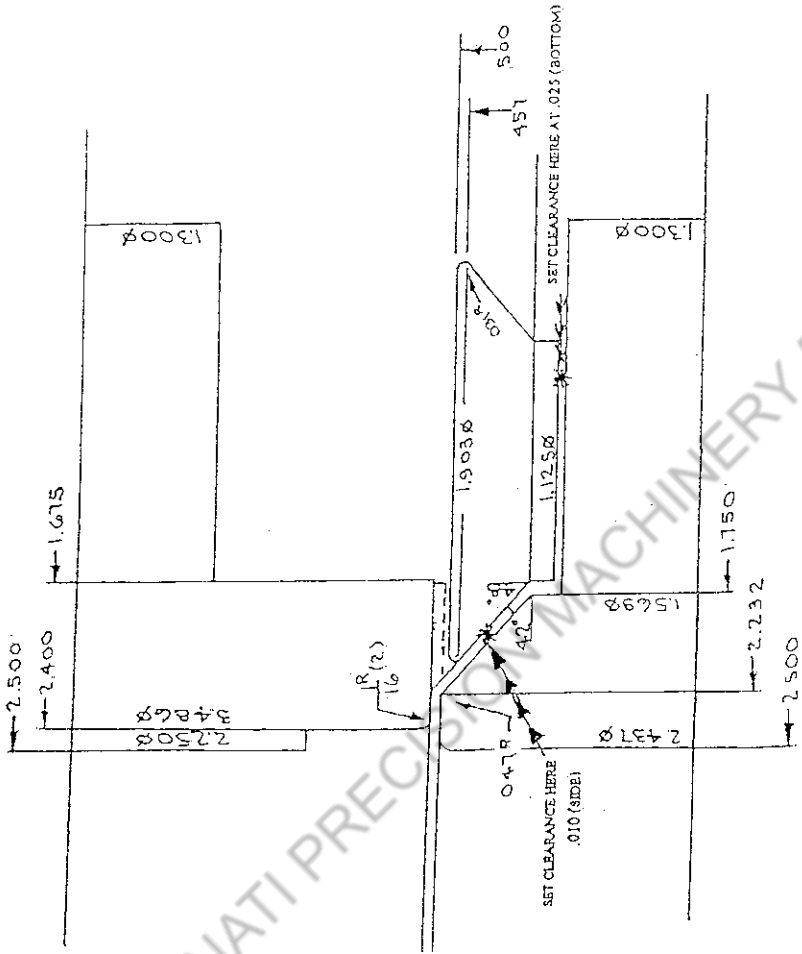

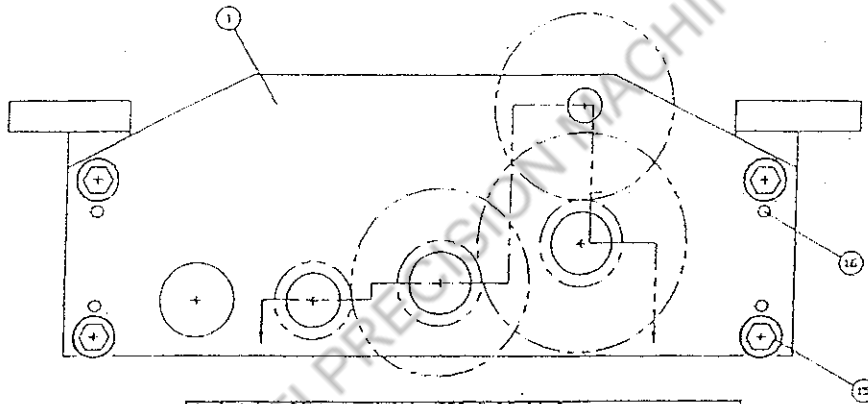
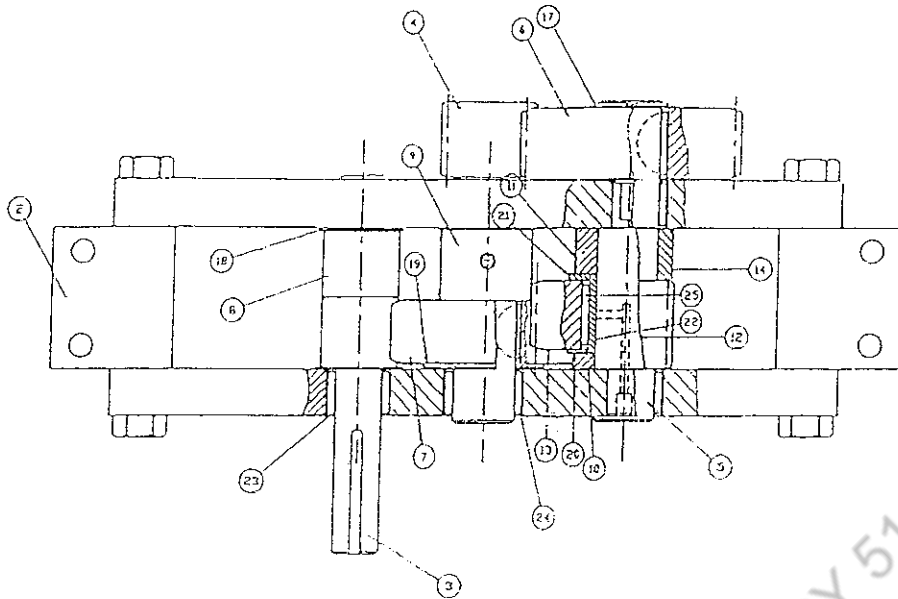

25	1	B-2016	X	NEEDLE BEARING	CORRECTED
24	4	JH-1612-DH	X	NEEDLE BEARING	CORRECTED
23	2	JH-1412-DH	X	NEEDLE BEARING	CORRECTED
22	1	IR-162020	X	INNER RACE	CORRECTED
21	1	TRC-2031	X	THRUST RACE	CORRECTED
20	1	TKB-2031	X	THRUST RACE	CORRECTED
19	6	TRA-1620	X	THRUST RACE	CORRECTED
18	3	TRA-1423	X	THRUST RACE	CORRECTED
17	1	5100-106	X	SNAP RING	CORRECT
16	0		X	SPRING PIN 3/16 X 1" LG.	
15	8		X	BOCY 1/2-20 X 1 1/4" LG. SHCS	
14	1	4145	X	SPACER-PINION #4	
13	1	4210-1	X	GEAR-IDLER	
12	1	9850	X	IDLER SHAFT	
11	1	9851-1	X	SPACER-IDLER SHAFT	
10	1	9851	X	SPACER-IDLER SHAFT	
9	1	4140	X	SPACER-PINION #3	
8	1	4147	X	SPACER-PRIMARY PINION	
7	1	4213	X	SPUR GEAR G-26	
6	1	4139	X	SPUR GEAR U-27	
5	1	4182	X	PINION #4	
4	1	4181	X	PINION #3	
3	1	4176	X	PINION-PRIMARY	
2	2	4174	X	MOUNT-SPLINE REDUCER	
1	2	4241	X	PINION CHASSIS	
SYMBOL		P/K		DESCRIPTION	
ENGEL INDUSTRIES		REDCORP		REDUCER ASSY.	
ST. LOUIS, MISSOURI		INC.		3 PINION (NEW STYLE)	
		ASSY. NO.		D-4144-1	

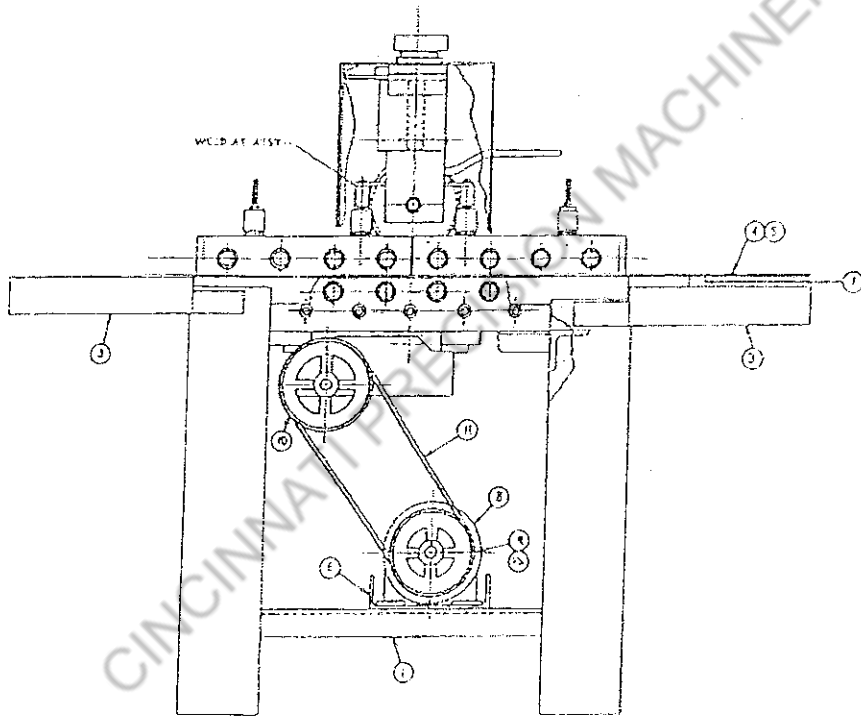
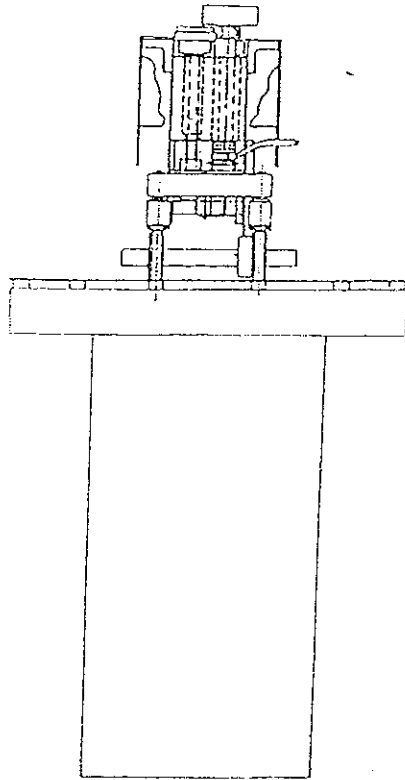

CINCINNATI PRECISION MACHINERY 513-860-4133

8	1	1877 FRAME	X	5 HP MOTOR
7	4	4251	X	SPACER TIE PLATE
	2	4978	X	MOTOR MOUNT ASSY
	3	4245-3	X	TIE PLATE ASSY LEFT
	1	4246-3	X	TIE PLATE ASSY RIGHT
3	2	4112	X	INFEED & OUTFEED TABLE ASSY
1	1	11087	X	SPINDLE HOUSING ASSY 825, 800-P
	1	4443, 4972	X	FRAME WELDMENT
		B-6-85	FINAL ASSEMBLY	
		SLR	825, 800-P SERIES	
			09671	

OPTIONAL
WITH TIE
WITH TIE

25	1	BK-LE 1 1/2 D	PK	SHEAVE (PROOVING)
23	1	9684	Z	FINAL ASSY 800-P 3/4-4 LUGMASTER
11	1	8K-42	J	BELT
10	1	GK-70 1/2 L	A	
9	1	BR-10, 1 1/2 D	Z	PROOVING SHEAVE

SEE TOWER FLANGE FOR OPTIONAL

YGEL INDUSTRIES, INC.
11 LOUISIANA

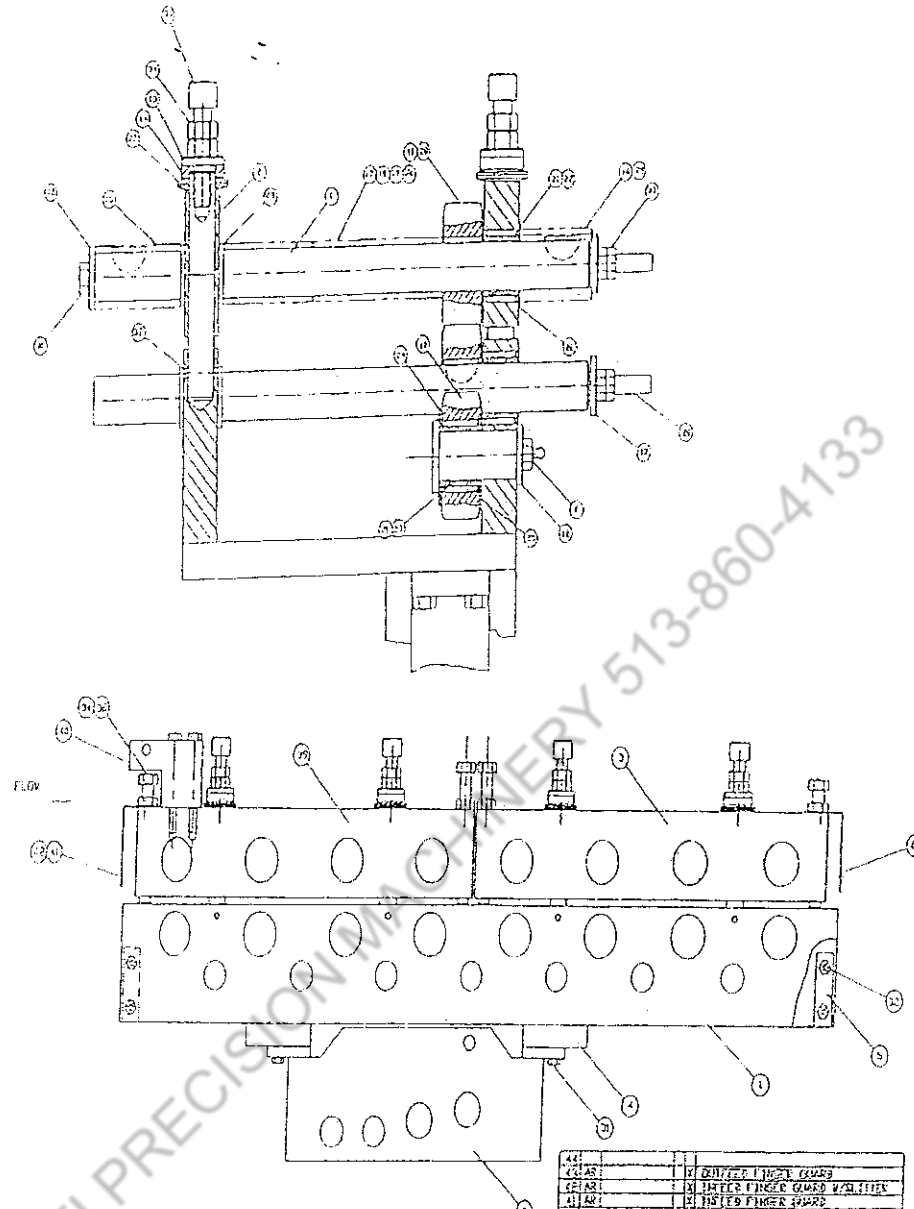

CINCINNATI PRECISION MECHANICAL WORKS 513-860-4133

441		Y	DIFFERENTIAL GEAR
442		Y	DIFFERENTIAL GEAR
443		Y	DIFFERENTIAL GEAR
444		Y	DIFFERENTIAL GEAR
445		Y	DIFFERENTIAL GEAR
446		Y	DIFFERENTIAL GEAR
447		Y	DIFFERENTIAL GEAR
448		Y	DIFFERENTIAL GEAR
449		Y	DIFFERENTIAL GEAR
450		Y	DIFFERENTIAL GEAR
451		Y	DIFFERENTIAL GEAR
452		Y	DIFFERENTIAL GEAR
453		Y	DIFFERENTIAL GEAR
454		Y	DIFFERENTIAL GEAR
455		Y	DIFFERENTIAL GEAR
456		Y	DIFFERENTIAL GEAR
457		Y	DIFFERENTIAL GEAR
458		Y	DIFFERENTIAL GEAR
459		Y	DIFFERENTIAL GEAR
460		Y	DIFFERENTIAL GEAR
461		Y	DIFFERENTIAL GEAR
462		Y	DIFFERENTIAL GEAR
463		Y	DIFFERENTIAL GEAR
464		Y	DIFFERENTIAL GEAR
465		Y	DIFFERENTIAL GEAR
466		Y	DIFFERENTIAL GEAR
467		Y	DIFFERENTIAL GEAR
468		Y	DIFFERENTIAL GEAR
469		Y	DIFFERENTIAL GEAR
470		Y	DIFFERENTIAL GEAR
471		Y	DIFFERENTIAL GEAR
472		Y	DIFFERENTIAL GEAR
473		Y	DIFFERENTIAL GEAR
474		Y	DIFFERENTIAL GEAR
475		Y	DIFFERENTIAL GEAR
476		Y	DIFFERENTIAL GEAR
477		Y	DIFFERENTIAL GEAR
478		Y	DIFFERENTIAL GEAR
479		Y	DIFFERENTIAL GEAR
480		Y	DIFFERENTIAL GEAR
481		Y	DIFFERENTIAL GEAR
482		Y	DIFFERENTIAL GEAR
483		Y	DIFFERENTIAL GEAR
484		Y	DIFFERENTIAL GEAR
485		Y	DIFFERENTIAL GEAR
486		Y	DIFFERENTIAL GEAR
487		Y	DIFFERENTIAL GEAR
488		Y	DIFFERENTIAL GEAR
489		Y	DIFFERENTIAL GEAR
490		Y	DIFFERENTIAL GEAR
491		Y	DIFFERENTIAL GEAR
492		Y	DIFFERENTIAL GEAR
493		Y	DIFFERENTIAL GEAR
494		Y	DIFFERENTIAL GEAR
495		Y	DIFFERENTIAL GEAR
496		Y	DIFFERENTIAL GEAR
497		Y	DIFFERENTIAL GEAR
498		Y	DIFFERENTIAL GEAR
499		Y	DIFFERENTIAL GEAR
500		Y	DIFFERENTIAL GEAR

ENCO INDUSTRIES, DC SPINDLE HOUSING ASSY.
 486-U ROLL 1424
 P-9016

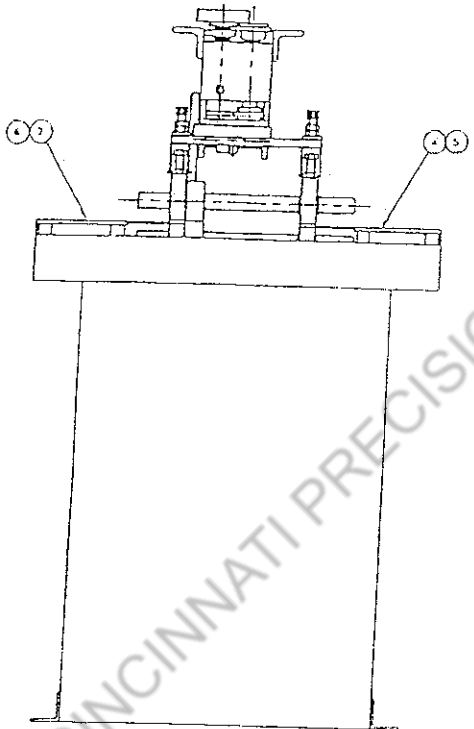
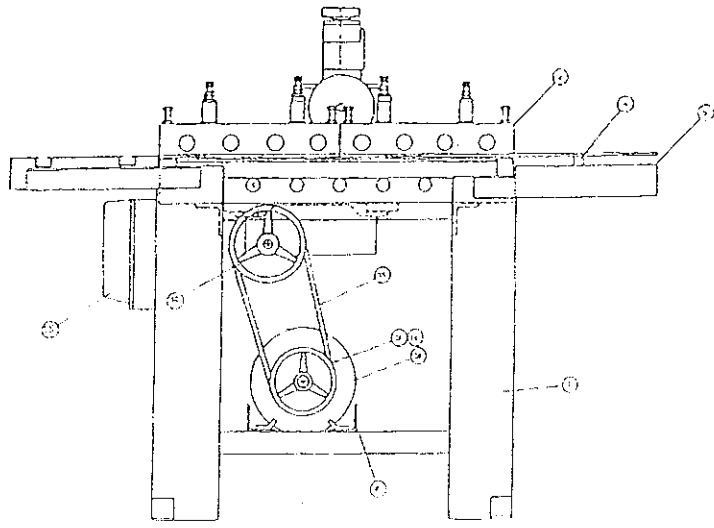

16	AR	D-9010-1		ENG - ENGINE MASTER
15	1	8P-1000	Y	MOTOR STARTER
14	1	8P-6P	Y	SHAVE (BRUWING)
13	1	8P-4P	Y	BELL (BRUWING)
12	1	8P-2P	N	SHAVE (BRUWING)
11	1	8P-1P	Y	SHAVE (BRUWING)
10	1	184-1	Y	ROTOR 3 HP
9	4	4001	Y	SPACE-TIE PLATE
8	P	9009	Y	MOTOR MOUNT ASSY.
7	AR	4246-3	Z	TIE PLATE (RIGHT SIDE B20)
6	AR	4246-1	Z	TIE PLATE (RIGHT SIDE B20)
5	AR	4245-1	Z	TIE PLATE (LEFT SIDE B20)
4	AR	4245-2	Z	TIE PLATE (LEFT SIDE B20)
3	J	4111	Z	IMPLD L BRITISH JAR ES
2	J	8016	Z	SPINDLE MOUNTING ASSY.
1	J	8017	Z	IM FRAME WELDMENT
DRAWN BY		ENG	DATE	APPROVED BY
ENGL INDUSTRIES INC		FINAL ASSY.		
21, LORAIN ROAD, WYOMING, DELAWARE		800-U ROLL MACH		
DISK #48		D-9010		