



OPERATOR'S MANUAL

Metal Working



MAGNETIC BOX AND PAN BRAKE MODEL: BB-4816M

Baileigh Industrial, Inc.
P.O. Box 531
Manitowoc, WI 54221-0531
Phone: 920.684.4990
Fax: 920.684.3944
sales@baileigh.com

REPRODUCTION OF THIS MANUAL IN ANY FORM WITHOUT WRITTEN APPROVAL OF BAILEIGH INDUSTRIAL, INC. IS PROHIBITED. Baileigh Industrial, Inc. does not assume and hereby disclaims any liability for any damage or loss caused by an omission or error in this Operator's Manual, resulting from accident, negligence, or other occurrence.



Table of Contents

THANK YOU & WARRANTY	1
INTRODUCTION.....	3
GENERAL NOTES.....	3
SAFETY INSTRUCTIONS	4
SAFETY PRECAUTIONS	6
Dear Valued Customer:.....	6
TECHNICAL SPECIFICATIONS.....	8
TECHNICAL SUPPORT	8
UNPACKING AND CHECKING CONTENTS.....	9
Cleaning	9
TRANSPORTING AND LIFTING	12
INSTALLATION.....	13
Anchoring the Machine.....	13
OVERALL DIMENSIONS.....	14
ASSEMBLY AND SET UP	15
Removing and Installing the Bending Extension Bar	16
ELECTRICAL.....	17
OPERATION.....	19
Magnetism Notes.....	21
BENDING ALLOWANCE	22
UNDERSTANDING SPRINGBACK	22
MATERIAL SELECTION.....	22
BEND CONFIGURATIONS.....	23
BENDING EXAMPLES	23
LUBRICATION AND MAINTENANCE	26
Checking Machine Accuracy	27
PARTS DIAGRAM	28
Parts List	29
ELECTRICAL COMPONENTS	31
ELECTRICAL SCHEMATIC.....	32
Electrical Components.....	33
TROUBLESHOOTING	34



THANK YOU & WARRANTY

Thank you for your purchase of a machine from Baileigh Industrial. We hope that you find it productive and useful to you for a long time to come.

Inspection & Acceptance. Buyer shall inspect all Goods within ten (10) days after receipt thereof. Buyer's payment shall constitute final acceptance of the Goods and shall act as a waiver of the Buyer's rights to inspect or reject the goods unless otherwise agreed. If Buyer rejects any merchandise, Buyer must first obtain a Returned Goods Authorization ("RGA") number before returning any goods to Seller. Goods returned without a RGA will be refused. Seller will not be responsible for any freight costs, damages to goods, or any other costs or liabilities pertaining to goods returned without a RGA. Seller shall have the right to substitute a conforming tender. Buyer will be responsible for all freight costs to and from Buyer and repackaging costs, if any, if Buyer refuses to accept shipment. If Goods are returned in unsalable condition, Buyer shall be responsible for full value of the Goods. Buyer may not return any special order Goods. Any Goods returned hereunder shall be subject to a restocking fee equal to 30% of the invoice price.

Specifications. Seller may, at its option, make changes in the designs, specifications or components of the Goods to improve the safety of such Goods, or if in Seller's judgment, such changes will be beneficial to their operation or use. Buyer may not make any changes in the specifications for the Goods unless Seller approves of such changes in writing, in which event Seller may impose additional charges to implement such changes.

Limited Warranty. Seller warrants to the original end-user that the Goods manufactured or provided by Seller under this Agreement shall be free of defects in material or workmanship for a period of twelve (12) months from the date of purchase, provided that the Goods are installed, used, and maintained in accordance with any instruction manual or technical guidelines provided by the Seller or supplied with the Goods, if applicable. The original end-user must give written notice to Seller of any suspected defect in the Goods prior to the expiration of the warranty period. The original end-user must also obtain a RGA from Seller prior to returning any Goods to Seller for warranty service under this paragraph. Seller will not accept any responsibility for Goods returned without a RGA. The original end-user shall be responsible for all costs and expenses associated with returning the Goods to Seller for warranty service. In the event of a defect, Seller, at its sole option, shall repair or replace the defective Goods or refund to the original end-user the purchase price for such defective Goods. Goods are not eligible for replacement or return after a period of 30 days from date of receipt. The foregoing warranty is Seller's sole obligation, and the original end-user's exclusive remedy, with regard to any defective Goods. This limited warranty does not apply to: (a) die sets, tooling, and saw blades; (b) periodic or routine maintenance and setup, (c) repair or replacement of the Goods due to normal wear and tear, (d) defects or damage to the Goods resulting from misuse, abuse, neglect, or accidents, (e) defects or damage to the Goods resulting from improper or unauthorized alterations, modifications, or changes; and (f) any Goods that has not been installed and/or maintained in accordance with the instruction manual or technical guidelines provided by Seller.

EXCLUSION OF OTHER WARRANTIES. THE FOREGOING LIMITED WARRANTY IS IN LIEU OF ALL OTHER WARRANTIES, EXPRESS OR IMPLIED. ANY AND ALL OTHER EXPRESS, STATUTORY OR IMPLIED WARRANTIES, INCLUDING BUT NOT LIMITED TO, ANY WARRANTY OF MERCHANTABILITY OR FITNESS FOR ANY PARTICULAR PURPOSE ARE EXPRESSLY DISCLAIMED. NO WARRANTY IS MADE WHICH EXTENDS BEYOND THAT WHICH IS EXPRESSLY CONTAINED HEREIN.

Limitation of Liability. IN NO EVENT SHALL SELLER BE LIABLE TO BUYER OR ANY OTHER PARTY FOR ANY INCIDENTAL, CONSEQUENTIAL OR SPECIAL DAMAGES (INCLUDING, WITHOUT LIMITATION, LOST PROFITS OR DOWN TIME) ARISING FROM OR IN MANNER CONNECTED WITH THE GOODS, ANY BREACH BY SELLER OR ITS AGENTS OF THIS AGREEMENT, OR ANY OTHER CAUSE WHATSOEVER, WHETHER BASED ON CONTRACT, TORT OR ANY OTHER THEORY OF LIABILITY. BUYER'S REMEDY WITH RESPECT TO ANY CLAIM ARISING UNDER THIS AGREEMENT IS STRICTLY LIMITED TO NO MORE THAN THE AMOUNT PAID BY THE BUYER FOR THE GOODS.



Force Majeure. Seller shall not be responsible for any delay in the delivery of, or failure to deliver, Goods due to causes beyond Seller's reasonable control including, without limitation, acts of God, acts of war or terrorism, enemy actions, hostilities, strikes, labor difficulties, embargoes, non-delivery or late delivery of materials, parts and equipment or transportation delays not caused by the fault of Seller, delays caused by civil authorities, governmental regulations or orders, fire, lightening, natural disasters or any other cause beyond Seller's reasonable control. In the event of any such delay, performance will be postponed by such length of time as may be reasonably necessary to compensate for the delay.

Installation. If Buyer purchases any Goods that require installation, Buyer shall, at its expense, make all arrangements and connections necessary to install and operate the Goods. Buyer shall install the Goods in accordance with any Seller instructions and shall indemnify Seller against any and all damages, demands, suits, causes of action, claims and expenses (including actual attorneys' fees and costs) arising directly or indirectly out of Buyer's failure to properly install the Goods.

Work By Others; Safety Devices. Unless agreed to in writing by Seller, Seller has no responsibility for labor or work performed by Buyer or others, of any nature, relating to design, manufacture, fabrication, use, installation or provision of Goods. Buyer is solely responsible for furnishing, and requiring its employees and customers to use all safety devices, guards and safe operating procedures required by law and/or as set forth in manuals and instruction sheets furnished by Seller. Buyer is responsible for consulting all operator's manuals, ANSI or comparable safety standards, OSHA regulations and other sources of safety standards and regulations applicable to the use and operation of the Goods.

Remedies. Each of the rights and remedies of Seller under this Agreement is cumulative and in addition to any other or further remedies provided under this Agreement or at law or equity.

Attorney's Fees. In the event legal action is necessary to recover monies due from Buyer or to enforce any provision of this Agreement, Buyer shall be liable to Seller for all costs and expenses associated therewith, including Seller's actual attorneys' fees and costs.

Governing Law/Venue. This Agreement shall be construed and governed under the laws of the State of Wisconsin, without application of conflict of law principles. Each party agrees that all actions or proceedings arising out of or in connection with this Agreement shall be commenced, tried, and litigated only in the state courts sitting in Manitowoc County, Wisconsin or the U.S. Federal Court for the Eastern District of Wisconsin. Each party waives any right it may have to assert the doctrine of "forum non conveniens" or to object to venue to the extent that any proceeding is brought in accordance with this section. Each party consents to and waives any objection to the exercise of personal jurisdiction over it by courts described in this section. Each party waives to the fullest extent permitted by applicable law the right to a trial by jury.

Summary of Return Policy.

- 10 Day acceptance period from date of delivery. Damage claims and order discrepancies will not be accepted after this time.
- You must obtain a Baileigh issued RGA number PRIOR to returning any materials.
- Returned materials must be received at Baileigh in new condition and in original packaging.
- Altered items are not eligible for return.
- Buyer is responsible for all shipping charges.
- A 30% re-stocking fee applies to all returns.

Baileigh Industrial makes every effort to ensure that our posted specifications, images, pricing and product availability are as correct and timely as possible. We apologize for any discrepancies that may occur. Baileigh Industrial reserves the right to make any and all changes deemed necessary in the course of business including but not limited to pricing, product specifications, quantities, and product availability.

For Customer Service & Technical Support:

Please contact one of our knowledgeable Sales and Service team members at:
(920) 684-4990 or e-mail us at sales@baileigh.com



INTRODUCTION

The quality and reliability of the components assembled on a Baileigh Industrial machine guarantee near perfect functioning, free from problems, even under the most demanding working conditions. However if a situation arises, refer to the manual first. If a solution cannot be found, contact the distributor where you purchased our product. Make sure you have the serial number and production year of the machine (stamped on the nameplate). For replacement parts refer to the assembly numbers on the parts list drawings.

Our technical staff will do their best to help you get your machine back in working order.

In this manual you will find: (when applicable)

- Safety procedures
- Correct installation guidelines
- Description of the functional parts of the machine
- Capacity charts
- Set-up and start-up instructions
- Machine operation
- Scheduled maintenance
- Parts lists

GENERAL NOTES

After receiving your equipment remove the protective container. Do a complete visual inspection, and if damage is noted, **photograph it for insurance claims** and contact your carrier at once, requesting inspection. Also contact Baileigh Industrial and inform them of the unexpected occurrence. Temporarily suspend installation.

Take necessary precautions while loading / unloading or moving the machine to avoid any injuries.

Your machine is designed and manufactured to work smoothly and efficiently. Following proper maintenance instructions will help ensure this. Try and use original spare parts, whenever possible, and most importantly; **DO NOT** overload the machine or make any modifications.



Note: This symbol refers to useful information throughout the manual.



IMPORTANT **PLEASE READ THIS OPERATORS MANUAL CAREFULLY**

It contains important safety information, instructions, and necessary operating procedures. The continual observance of these procedures will help increase your production and extend the life of the equipment.



SAFETY INSTRUCTIONS

LEARN TO RECOGNIZE SAFETY INFORMATION

This is the safety alert symbol. When you see this symbol on your machine or in this manual, **BE ALERT TO THE POTENTIAL FOR PERSONAL INJURY!**

Follow recommended precautions and safe operating practices.

UNDERSTAND SIGNAL WORDS

A signal word – **DANGER**, **WARNING**, or **CAUTION** is used with the safety alert symbol. **DANGER** identifies a hazard or unsafe practice that will result in severe **Injury or Death.**

Safety signs with signal word **DANGER** or **WARNING** are typically near specific hazards.

General precautions are listed on **CAUTION** safety signs. **CAUTION** also calls attention to safety messages in this manual.



DANGER



WARNING



CAUTION



SAVE THESE INSTRUCTIONS.
Refer to them often and use them to instruct others.



PROTECT EYES

Wear safety glasses or suitable eye protection when working on or around machinery.

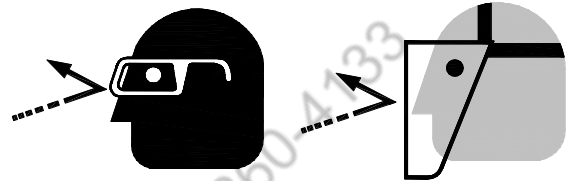

BEWARE OF CRUSH HAZARD

Placing fingers or hands between the clamping leaf and the magnetic bed could cause serious personal injury. NEVER place any part of your body in the bending mechanism of the machine.

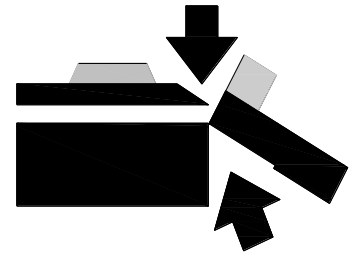

KEEP CLEAR OF MOVING OBJECTS

Always be aware of the position of the clamp handle and the counterweight. They are heavy and can swing back suddenly causing serious body or head injuries.

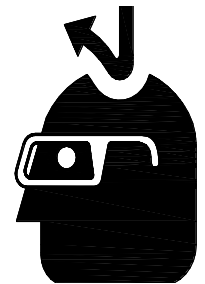

ELECTRICAL AND MAGNETIC FIELDS

Electric current and magnetic fields (EMF). These magnetic fields can have an effect on pacemakers, medical implant, sensitive electronic equipment, and loose metallic objects. Persons with a pacemaker or medical implant must stay back at least 12 inches (30cm). Prolonged exposure to EMF may have other health effects which are not yet known.

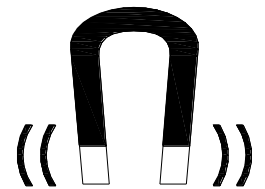

HIGH VOLTAGE

USE CAUTION IN HIGH VOLTAGE AREAS. DO NOT assume the power to be off.
FOLLOW PROPER LOCKOUT PROCEDURES.

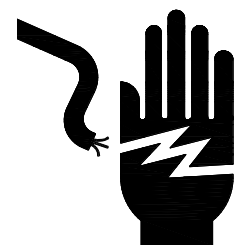



SAFETY PRECAUTIONS



Metal working can be dangerous if safe and proper operating procedures are not followed. As with all machinery, there are certain hazards involved with the operation of the product. Using the machine with respect and caution will considerably lessen the possibility of personal injury. However, if normal safety precautions are overlooked or ignored, personal injury to the operator may result.

Safety equipment such as guards, hold-downs, safety glasses, dust masks and hearing protection can reduce your potential for injury. But even the best guard won't make up for poor judgment, carelessness or inattention. **Always use common sense** and exercise **caution** in the workshop. If a procedure feels dangerous, don't try it.

REMEMBER: Your personal safety is your responsibility.



WARNING: FAILURE TO FOLLOW THESE RULES MAY RESULT IN SERIOUS PERSONAL INJURY

Dear Valued Customer:

- All Baileigh machines should be used only for their intended use.
- Baileigh does not recommend or endorse making any modifications or alterations to a Baileigh machine. Modifications or alterations to a machine may pose a substantial risk of injury to the operator or others and may do substantial damage to the machine.
- Any modifications or alterations to a Baileigh machine will invalidate the machine's warranty.

PLEASE ENJOY YOUR BAILEIGH MACHINE!PLEASE ENJOY IT SAFELY!

1. **FOR YOUR OWN SAFETY, READ INSTRUCTION MANUAL BEFORE OPERATING THE MACHINE.** Learn the machine's application and limitations as well as the specific hazards.
2. **Only trained and qualified personnel can operate this machine.**
3. **Make sure guards are in place and in proper working order before operating machinery.**
4. **Remove any adjusting tools.** Before operating the machine, make sure any adjusting tools have been removed.
5. **Keep work area clean.** Cluttered areas invite injuries.
6. **Overloading machine.** By overloading the machine, you may cause injury from flying parts. **DO NOT** exceed the specified machine capacities.



7. **Dressing material edges.** Always chamfer and deburr all sharp edges.
8. **Do not force tool.** Your machine will do a better and safer job if used as intended. **DO NOT** use inappropriate attachments in an attempt to exceed the machines rated capacity.
9. **Use the right tool for the job. DO NOT** attempt to force a small tool or attachment to do the work of a large industrial tool. **DO NOT** use a tool for a purpose for which it was not intended.
10. **Dress appropriate. DO NOT** wear loose fitting clothing or jewelry as they can be caught in moving machine parts. Protective clothing and steel toe shoes are recommended when using machinery. Wear a restrictive hair covering to contain long hair.
11. **Use eye and ear protection.** Always wear ISO approved impact safety goggles. Wear a full-face shield if you are producing metal filings.
12. **Do not overreach.** Maintain proper footing and balance at all times. **DO NOT** reach over or across a running machine.
13. **Stay alert.** Watch what you are doing and use common sense. **DO NOT** operate any tool or machine when you are tired.
14. **Check for damaged parts.** Before using any tool or machine, carefully check any part that appears damaged. Check for alignment and binding of moving parts that may affect proper machine operation.
15. **Observe work area conditions. DO NOT** use machines or power tools in damp or wet locations. Do not expose to rain. Keep work area well lighted. **DO NOT** use electrically powered tools in the presence of flammable gases or liquids.
16. **Keep children away.** Children must never be allowed in the work area. **DO NOT** let them handle machines, tools, or extension cords.
17. **Store idle equipment.** When not in use, tools must be stored in a dry location to inhibit rust. Always lock up tools and keep them out of reach of children.
18. **DO NOT operate machine if under the influence of alcohol or drugs.** Read warning labels on prescriptions. If there is any doubt, **DO NOT** operate the machine.
19. **Turn off** power before checking, cleaning, or replacing any parts.
20. Be sure **all** equipment is properly installed and grounded according to national, state, and local codes.
21. Keep **all** cords dry, free from grease and oil, and protected from sparks and hot metal.
22. Inspect power and control cables periodically. Replace if damaged or bare wires are exposed. **Bare wiring can kill! DO NOT** touch live electrical components or parts.
23. **DO NOT** bypass or defeat any safety interlock systems.
24. Keep visitors a safe distance from the work area.



TECHNICAL SPECIFICATIONS

Bend Length	48" (1220mm)
Bend Material Thickness	16ga. (1.51mm) mild steel*
Bending Leaf Extension Removed	20ga. (0.91mm) stainless steel**
Bend Material Thickness	18ga. (1.21mm) mild steel*
Bending Leaf Extension Installed	21ga. (0.83mm) stainless steel**
Bend Angle	0 – 180 degrees
Box Depth	Unlimited
Clamping Force	6 ton (5443kg)
Minimum Depth Under Clamping Bar	2" (51mm)
Power	220V (±5%), 1ph, 60hz, 12A
Duty Cycle	30%
Thermal Cut-Out	158°F (70°C)
Shipping Dimensions (L x W x H)	57" x 44" x 15" (1753 x 787 x 914mm)
Shipping Weight	1276 lbs. (462 kg)
Based on a material tensile strength of *64000 PSI – mild steel **100000 PSI – stainless steel	
‡Maximum capacity listed is obtained with the bending leaf extension removed.	

TECHNICAL SUPPORT

Our technical support department can be reached at 920.684.4990, and asking for the support desk for purchased machines. Tech Support handles questions on machine setup, schematics, warranty issues, and individual parts needs: (other than die sets and blades).

For specific application needs or future machine purchases contact the Sales Department at: sales@baileigh.com, Phone: 920.684.4990, or Fax: 920.684.3944.



Note: The photos and illustrations used in this manual are representative only and may not depict the actual color, labeling or accessories and may be intended to illustrate technique only.



Note: The specifications and dimensions presented here are subject to change without prior notice due to improvements of our products.



UNPACKING AND CHECKING CONTENTS

Your Baileigh machine is shipped complete. Separate all parts from the packing material and check each item carefully. Make certain all items are accounted for before discarding any packing material.

⚠ WARNING: SUFFOCATION HAZARD! Immediately discard any plastic bags and packing materials to eliminate choking and suffocation hazards to children and animals.
If any parts are missing, **DO NOT** place the machine into service until the missing parts are obtained and installed correctly.

Cleaning

⚠ WARNING: DO NOT USE gasoline or other petroleum products to clean the machine. They have low flash points and can explode or cause fire.

⚠ CAUTION: When using cleaning solvents work in a well-ventilated area. Many cleaning solvents are toxic if inhaled.

Your machine may be shipped with a rustproof waxy coating and/or grease on the exposed unpainted metal surfaces. Fully and completely remove this protective coating using a degreaser or solvent cleaner. Moving items will need to be moved along their travel path to allow for cleaning the entire surface. For a more thorough cleaning, some parts will occasionally have to be removed. **DO NOT USE** acetone or brake cleaner as they may damage painted surfaces.

Follow manufacturer's label instructions when using any type of cleaning product. After cleaning, wipe unpainted metal surfaces with a light coating of quality oil or grease for protection.



Important: This waxy coating is **NOT** a lubricant and will cause the machine to stick and lose performance as the coating continues to dry.





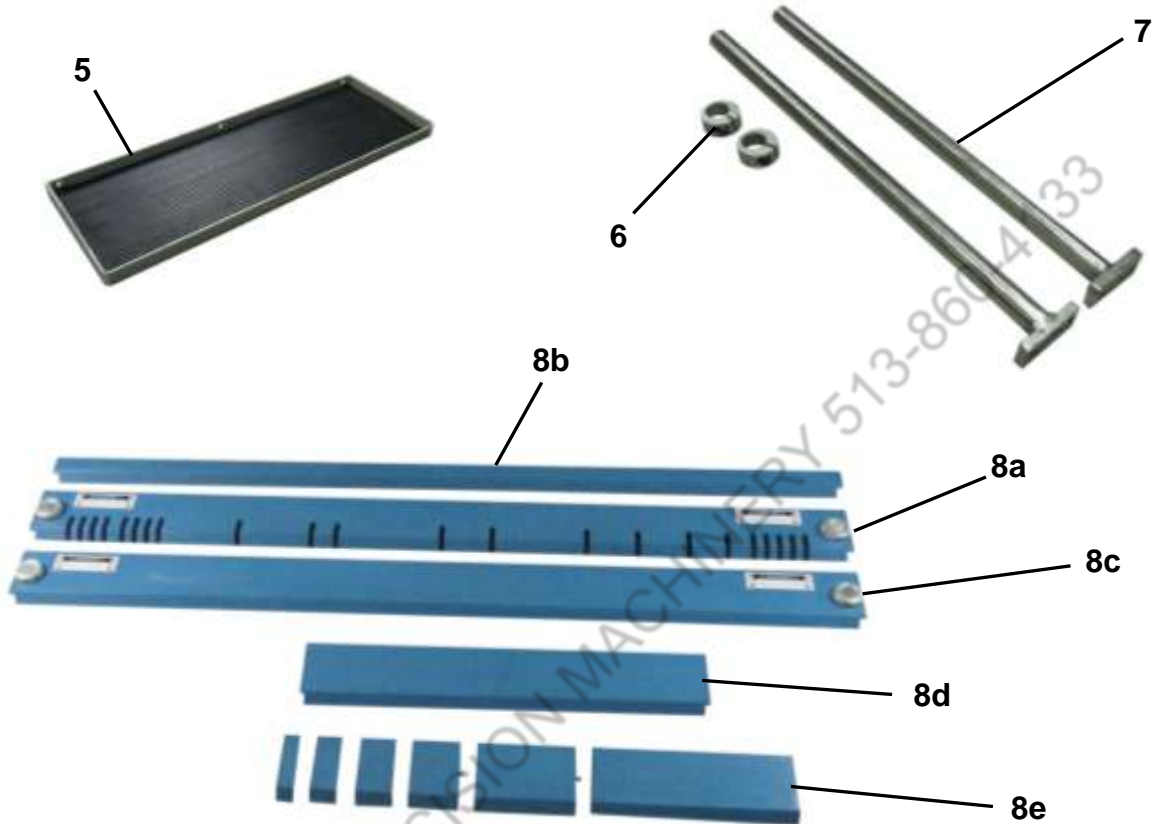

Item	Name	Qty.
1	Body and Pedestal	1
2	Footswitch	1
3	Back Feet	2
4	Front Feet	2
5	Tool Tray	1
6	Back Stop Collars	2
7	Back Stop Bars	2
8a	Notched Clamping Bar – Long	1
8b	Narrow Clamp Bar	1
8c	Wide Clamp Bar – Long	1
8d	Wide Clamp Bar – Short	1
8e	Segmented Clamp Bar (Assortment)	1
9	Bag of Hardware	1



TRANSPORTING AND LIFTING



IMPORTANT: *Lifting and carrying operations should be carried out by skilled workers, such as a truck operator, crane operator, etc. If a crane is used to lift the machine, attach the lifting chain carefully, making sure the machine is well balanced.*

Follow these guidelines when lifting with truck or trolley:

- The lift truck must be able to lift at least 1.5 – 2 times the machines gross weight.
- Make sure the machine is balanced. While transporting, avoid rough or jerky motion, and maintain a safe clearance zone around the transport area.
- Use a fork lift with sufficient lifting capacity and forks that are long enough to reach the complete width of the machine.
- Remove the securing bolts that attach the machine to the pallet.
- Approaching the machine from the side, lift the machine on the frame taking care that there are no cables or pipes in the area of the forks.
- Move the machine to the required position and lower gently to the floor.
- Level the machine so that all the supporting feet are taking the weight of the machine and no rocking is taking place.

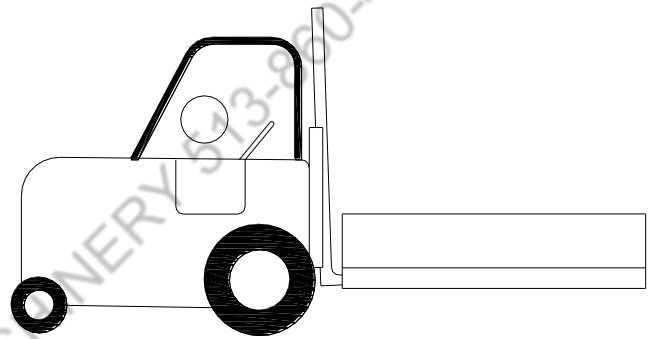

Follow these guidelines when lifting crane or hoist:

- Always lift and carry the machine with the lifting holes provided at the top of the machine.
- Use lift equipment such as straps, chains, capable of lifting 1.5 to 2 times the weight of the machine.
- Take proper precautions for handling and lifting.
- Check if the load is properly balanced by lifting it an inch or two.
- Lift the machine, avoiding sudden accelerations or quick changes of direction.
- Locate the machine where it is to be installed, and lower slowly until it touches the floor.



INSTALLATION

IMPORTANT:

Consider the following when looking for a suitable location to place the machine:

- Overall weight of the machine.
- Weight of material being processed.
- Sizes of material to be processed through the machine.
- Space needed for auxiliary stands, work tables, or other machinery.
- Clearance from walls and other obstacles.
- Maintain an adequate working area around the machine for safety.
- Have the work area well illuminated with proper lighting.
- Keep the floor free of oil and make sure it is not slippery.
- Remove scrap and waste materials regularly, and make sure the work area is free from obstructing objects.
- If long lengths of material are to be fed into the machine, make sure that they will not extend into any aisles.
- **LEVELING:** The machine should be sited on a level, concrete floor. Provisions for securing it should be in position prior to placing the machine. The accuracy of any machine depends on the precise placement of it to the mounting surface.
- **FLOOR:** This tool distributes a large amount of weight over a small area. Make certain that the floor is capable of supporting the weight of the machine, work stock, and the operator. The floor should also be a level surface. If the unit wobbles or rocks once in place, be sure to eliminate by using shims.
- **WORKING CLEARANCES:** Take into consideration the size of the material to be processed. Make sure that you allow enough space for you to operate the machine freely.
- **POWER SUPPLY PLACEMENT:** The power supply should be located close enough to the machine so that the power cord is not in an area where it would cause a tripping hazard. Be sure to observe all electrical codes if installing new circuits and/or outlets.

Anchoring the Machine

- Once positioned, anchor the machine to the floor, as shown in the diagram. Use bolts and expansion plugs or sunken tie rods that connect through and are sized for the holes in the base of the stand.
- This machine requires a solid floor such as concrete at a minimum of 4" (102mm) thick. 6" (153mm) minimum is preferred.

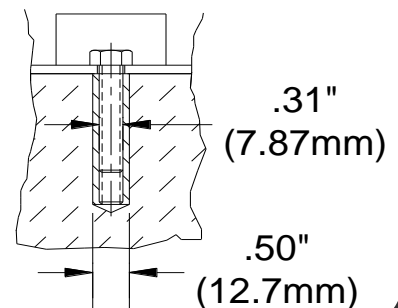



OVERALL DIMENSIONS

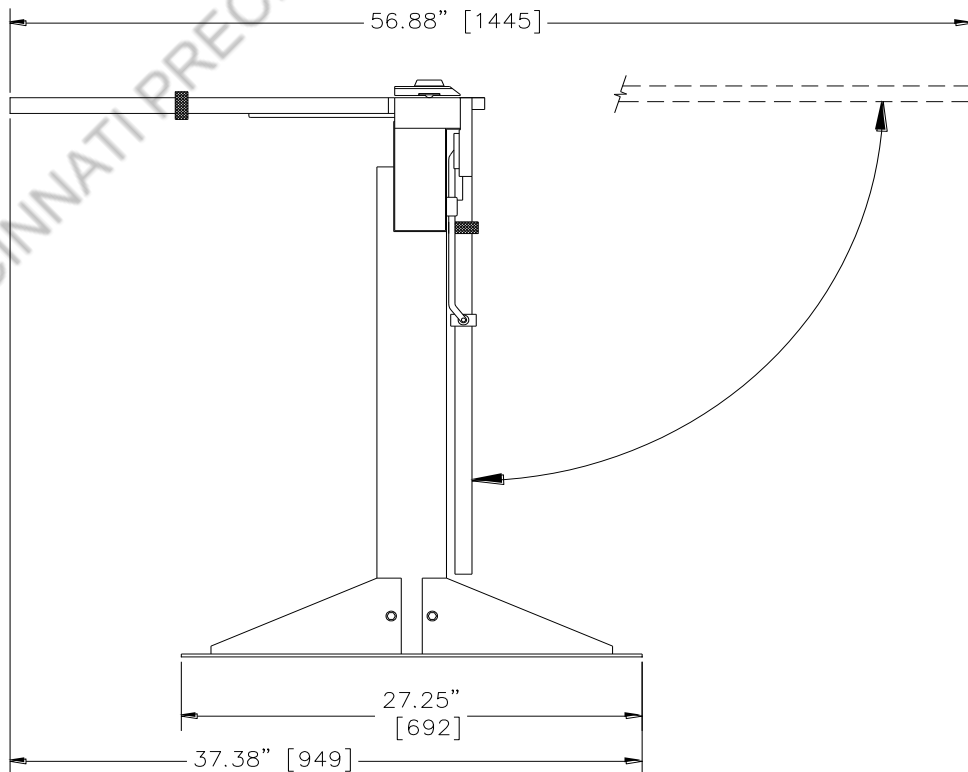
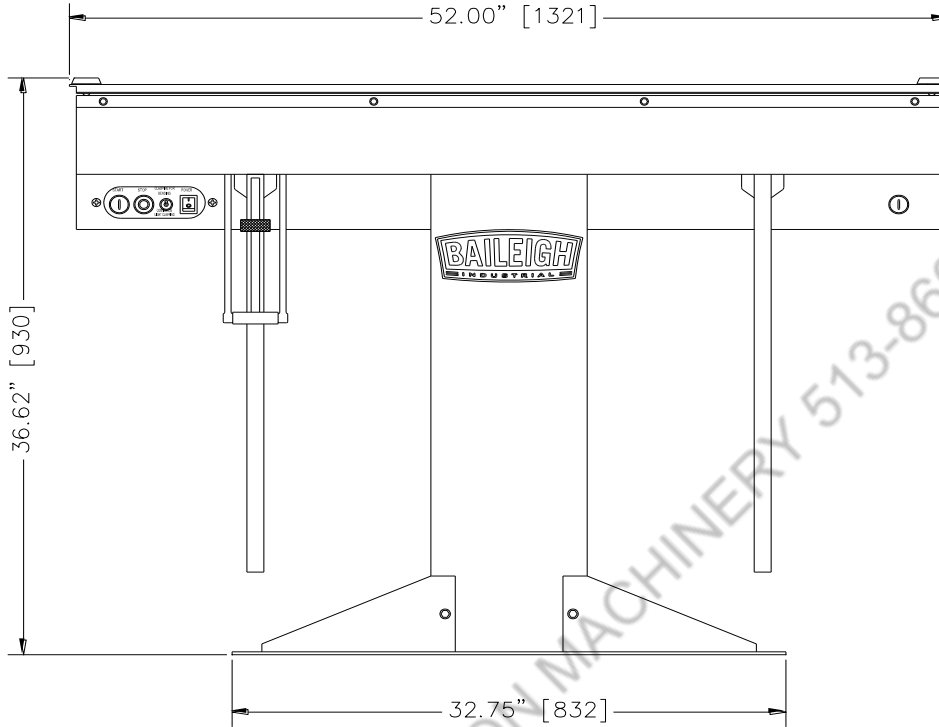



ASSEMBLY AND SET UP

⚠ WARNING: For your own safety, **DO NOT** connect the machine to the power source until the machine is completely assembled and you read and understand the entire instruction manual.

Attaching the Legs

1. With the help of another individual, raise the support column to a vertical position as shown in (fig. 3).
2. Attach each foot with (2) M10x16 button head screws (provided). The two feet with the safety tape will be on the front of the brake. (the side with the Baileigh logo).
3. Tighten the button head screws securely.
4. Carefully lay the brake on its side and then place in an upright position with a suitable lifting device.



figure 3

Tool Tray and Back Gauge Supports

1. Using (3) M8x12 socket cap screws attach the tool tray to the back of the brake.
2. Lay the rubber mat into the tray.
3. Attach each back gauge bar to the brake with (2) M8x16 socket capscrews.
4. Tighten securely.
5. Slide a back gauge collar onto each bar as shown in (fig. 4).

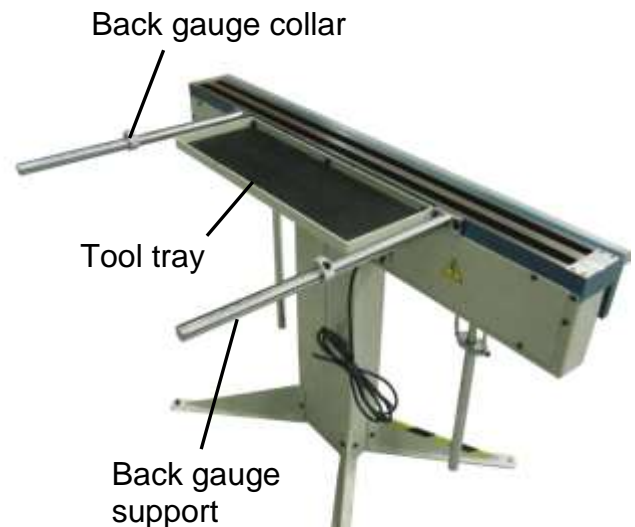

figure 4



Footswitch

1. Unstrap and straighten out the footswitch cable.
2. Grasp the connector end and plug into the receptacle at the back of the machine.
3. Tighten the connector sleeve.



figure 5

Removing and Installing the Bending Extension Bar



Note: For mild steel, 16ga., extension OFF. 18ga. extension On or Off, 20ga. and thinner, extension On.

1. Use a marker to mark the top surface of the extension bar.
2. Remove and retain the mounting bolts (A) and remove the extension bar and store with the clamping bars.
3. When installing the extension bar, verify that the bar and the seat on the bending leaf are clean (B) and that no metal chips or dirt will prevent the bar from setting fully into the bending leaf seat.
4. Install the mounting bolts (A) loosely.
5. Verify that the top of the extension bar is flush with the top surface of the bending leaf and tighten the mounting bolts keeping the surfaces flush.

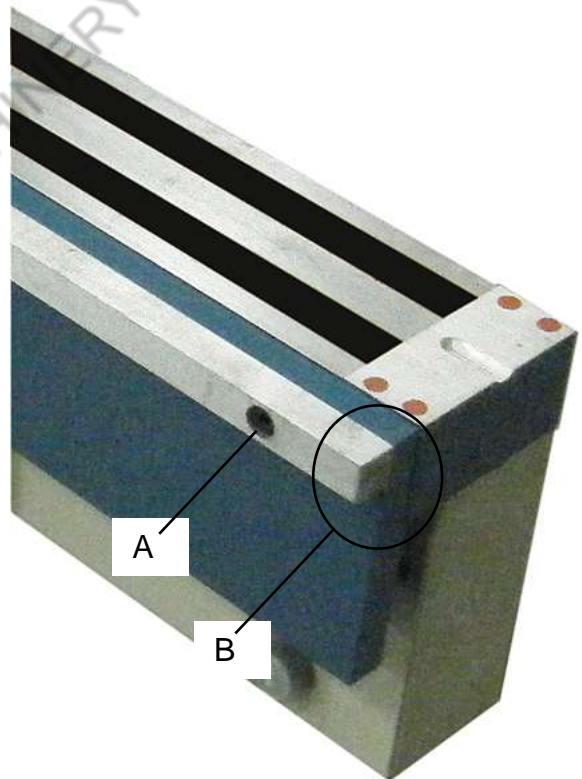



ELECTRICAL

⚠ CAUTION: HAVE ELECTRICAL UTILITIES CONNECTED TO MACHINE BY A CERTIFIED ELECTRICIAN!

Check if the available power supply is the same as listed on the machine nameplate.

⚠ WARNING: Make sure the grounding wire (green) is properly connected to avoid electric shock. DO NOT switch the position of the green grounding wire if any electrical plug wires are switched during hookup.

Power Specifications

Your tool is wired for 220 volts, 60Hz alternating current. Before connecting the tool to the power source, make sure the machine is cut off from power source.

Before switching on the power, you must check the voltage and frequency of the power to see if they meet with the requirement. The allowed range for the voltage is $\pm 5\%$, and for the frequency is $\pm 1\%$.

⚠ IMPORTANT: To achieve proper performance and prevent damage, the power supplied to this machine must be 220VAC $\pm 5\%$ (209VAC to 231VAC). Failure to comply will damage the machine and void the warranty. If needed, contact Baileigh Industrial at 920-684-4990 to purchase a Buck Boost transformer. The service personal will be able to assist in placing the order for the transformer or provide specifications so that you will be able to obtain the proper transformer for your application. Buck-Boost transformers are small single phase transformers designed to lower (buck) or raise (boost) line voltage from 5-20%.

Considerations

- Observe local electrical codes when connecting the machine.
- The circuit should be protected with a time delay fuse or circuit breaker with a amperage rating slightly higher than the full load current of machine.
- A separate electrical circuit should be used for your tools. Before connecting the motor to the power line, make sure the switch is in the "OFF" position and be sure that the electric current is of the same characteristics as indicated on the tool.
- All line connections should make good contact. Running on low voltage will damage the motor.
- In the event of a malfunction or breakdown, grounding provides a path of least resistance for electric current to reduce the risk of electric shock. This tool is equipped with an electric cord having an equipment-grounding conductor and a grounding plug. The plug must be plugged into a matching outlet that is properly installed and grounded in accordance with all local codes and ordinances.



⚠ WARNING: In all cases, make certain the receptacle in question is properly grounded. If you are not sure, have a qualified electrician check the receptacle.

- Improper connection of the equipment-grounding conductor can result in risk of electric shock. The conductor with insulation having an outer surface that is green with or without yellow stripes is the equipment-grounding conductor. If repair or replacement of the electric cord or plug is necessary, do not connect the equipment-grounding conductor to a live terminal.
- Check with a qualified electrician or service personnel if the grounding instructions are not completely understood, or if in doubt as to whether the tool is properly grounded.
- Repair or replace damaged or worn cord immediately.

Power cord connection:

1. Verify that power is turned OFF on the control panel and the power source.
2. Unwrap the power cord and route the cord away from the machine toward the power supply.
 - a. Route the power cord so that it will NOT become entangled in the machine in any way.
 - b. Route the cord to the power supply in a way that does NOT create a trip hazard.
3. Connect the power cord to the power supply and check that the power cord has not been damaged during installation.
4. When the machine is clear of any obstruction. The main power switch may be turn ON to test the operation. Turn the switch OFF when the machine is not in operation.



OPERATION

⚠ CAUTION: Always wear proper eye protection with side shields, safety footwear, and leather gloves to protect from burrs and sharp edges. When handling large heavy materials make sure they are properly supported. Keep hands and fingers clear of the clamping beam. Stand off to the side of the machine to avoid getting hit with the bending apron as it comes up to bend. The bending brake poses a pinching hazard. Make sure no body part or clothing comes between the clamping bar and the bending leaf.



IMPORTANT: DO NOT run the magnetic brake without material between the clamping bar and the electromagnetic work bench. After releasing the electromagnet, residual magnetism could still hold down the clamp bar.

Sheet Metal Bending

1. If you are using the clamp bars with the lifting balls, make sure they are both properly seated in the pockets of the workbench. (fig. 6)
2. Remove or install the bending leaf extension as needed for the material to be formed. See specification page.



Note: Typically for mild steel, 16ga., extension OFF. 18ga. extension On or Off, 20ga. and thinner, extension On. When forming around round stock as in Rolling and Edge, the extension bar is typically installed. The bending leaf extension is shown installed.

3. Set the machine for the material thickness you will be bending. Raise the bending leaf 90° as shown in (fig. 7). Rotate the knobs on each end of the clamping bar which adjusts the setback distance gap. Set this gap at slightly more than the material thickness to achieve an accurate bend. There are three positions on the knobs (0 – 1 – 2) which are useful when doing repeat bending.

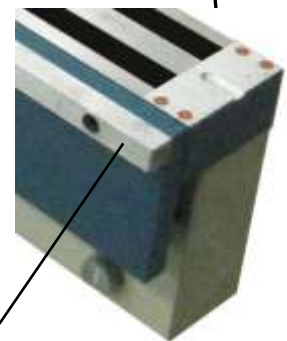

figure 6

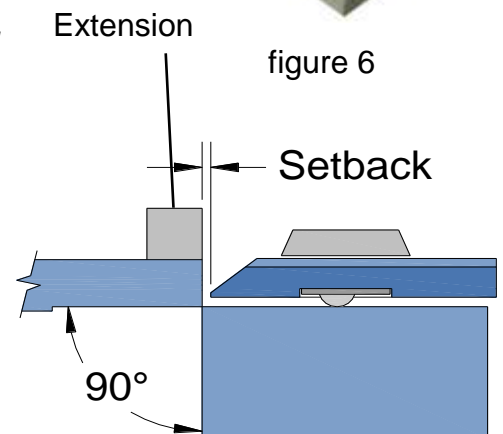

figure 7



- Press the RED power rocker switch to turn on the machine.
- Position the piece part under the clamp bar. Use the backstop if needed.
- To apply the pre-clamping force, step down on the footswitch or press either of the GREEN start switches. (See fig. 8 below) Now that the piece part is held in place, pull up on the bending leaf handles. This will activate the micro-switch which tells the electro-magnet to apply full clamping force. Continue pulling up on the handles until the desired bend angle is made.



figure 8

- The left handle has a leaf angle indicator that is shown in (fig. 9). To allow for springback of the material, bend a few degrees more than the required angle. Read the section Understanding springback. There is also a locking collar on the indicating shaft which can be set and locked to duplicate multiple bends.
- After the bend is made, lower the bending leaf.
- Press and HOLD IN the RED stop button (fig. 10) until the clamping bar releases. Release the red button.



figure 9

 **Important:** Each time the machine switches OFF, a short pulse of reverse current is sent through the electromagnet to demagnetize it as well as the piece part. Holding the red stop button for 2-3 full seconds help collapse the magnetic field.

- Reposition the piece part for the next bend and repeat steps 4 thru 7.
- For thicker gauge materials set the toggle switch in (fig. 10) to the CLAMPING FOR BENDING position. When bending very thin materials set the toggle switch to CONTINUOUS LIGHT CLAMPING.

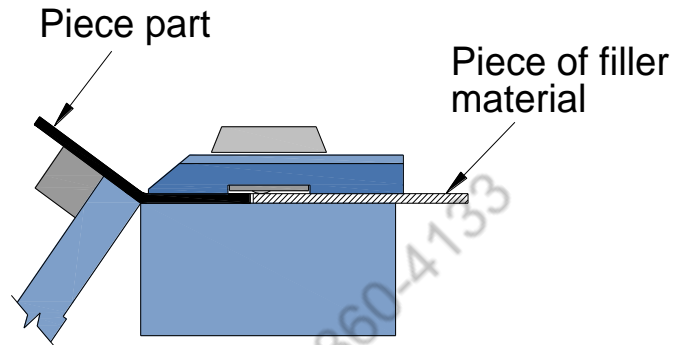

figure 10



Bending Edges of Materials

When bending a narrow lip (2" min. [51mm]) on a piece of material it is a good idea to place a piece of filler material under the clamping bar as shown in (fig. 11). This will support the clamping bar, allowing the bar to set flat across the brake body. Using a ferrous material as the filler will aid in maintaining strong magnetic adhesions.



Important: The material must be at least 2" (51mm) under the clamping bar plus a piece of filler material to allow for full clamping and bending force. Materials that do not extend to the full depth under the clamping bar will still pose issues with lifting before bending from time to time.

Magnetism Notes

Heat will reduce the strength of magnetic field. This is important to know when using the magnetic brake for long periods of time. It is recommended to keep the amount of time that the magnetic coils are energized as short as possible.

When the coils of the magnet are energized, the electrical current flowing through the coils creates heat. Keeping the brake in open air and if the ambient temperature is high, it may help to use an external fan to provide some air movement.



Important: If the bending bed, (magnet) is too hot to touch then the brake should be completely shut down and allowed to cool to prevent damage to the magnet coils.

Magnetic materials such as the steel used for the clamping bars will become weakly magnetized by being in contact with strong magnets. Over time with use, these bars will gain their own magnetic field. Over time when not in use, this magnetic field will dissipate and weaken.

If the magnetic brake is used daily, this relatively weak magnetic field will remain constant.

Also striking metal bars with a hammer can create a temporary weak magnet. This is important to know with regard to handling the clamping bars.

First, the clamping bars should be handled carefully to prevent damage and bending.

Additionally, if the bars are dropped or moved around roughly, this can cause the natural magnetic field created from usage to strengthen slightly as well as last longer.

This can cause some issues with the clamping bars releasing after a bend.

Use sources such as library or the internet to find methods for de-magnetizing steel if the clamping bars become too magnetized to use effectively.



BENDING ALLOWANCE

In order to bend sheet metal accurately, you will need to consider the total length of each bend. This is referred to as bend allowance. Subtract the bend allowance from the sum of the outside dimensions of the piece part to obtain the actual overall length or width of the piece. Because of differences in sheet metal hardness, and whether the bend is made with the grain or against it, exact allowances must sometimes be made by trial and error. However, bend allowances for general use can be obtained from metal working books or from the Internet.

UNDERSTANDING SPRINGBACK

Springback, also known as elastic recovery, is the result of the metal wanting to return to its original shape after undergoing compression and stretch. After the bending leaf is removed from the metal and the load is released, the piece part relaxes, forcing the bent portion of the metal to return slightly to its original shape. The key to obtaining the correct bend angle is to over bend the metal a little and allow it to spring back to the desired angle. All metals exhibit a certain amount of spring back.

MATERIAL SELECTION

⚠ CAUTION: It must be determined by the customer that materials being processed through the machine are NOT potentially hazardous to operator or personnel working nearby.

When selecting materials keep these instructions in mind:

- Material must be clean and dry. (without oil)
- Material should have a smooth surface so it processes easily.
- Dimensional properties of material must be consistent and not exceed the machine capacity values.
- Chemical structure of material must be consistent.
- Buy certificated steel from the same vendor when possible.



BEND CONFIGURATIONS

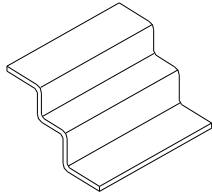

Return Bends

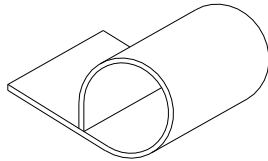

Rolled Edge

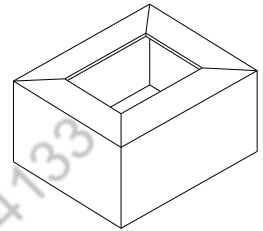

Box

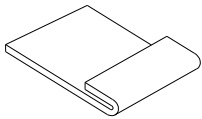

Hem

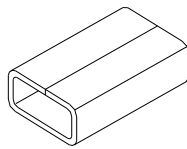

Closed Channel

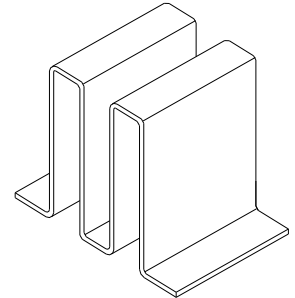

Fins

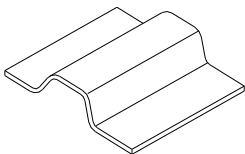

Stiffening Rib

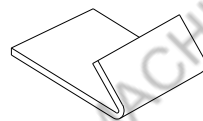

Angle Bend

BENDING EXAMPLES

Folding Over a Lip

The thickness, width, and length of material are factors to consider when folding a lip. DO NOT exceed 20ga. (.035") for material thickness.

1. With the clamping bar in place and properly secured, bend the material as far as the bending leaf will allow. (Normal bending procedure)
2. Now remove the clamping bar, bring up the bending leaf, and continue the fold as in (fig. 12). (No clamping is required.)
3. To further flatten the material, slide the piece part forward about 1/2" and use the bar to magnetically clamp it as shown in (fig. 13)

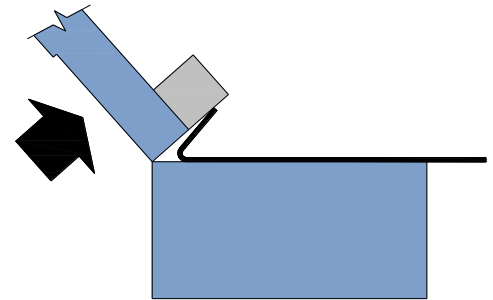

figure 12

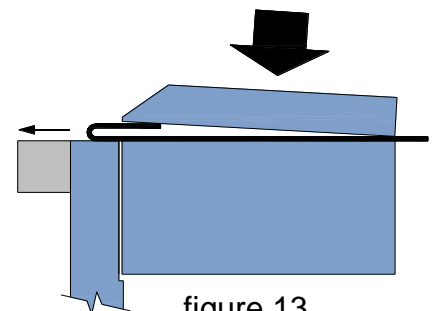

figure 13



Rolling an Edge

Use a piece of solid steel round or a pipe to accomplish this.

1. Position the clamping bar and the round bar as shown in (fig. 14) to ensure that the piece part is positioned correctly. Energize the electromagnet.
2. Raise the bending leaf to make the initial bend.
3. Release the electromagnet and rotate the piece part down to the horizontal position.
4. Continue the above procedure until you are satisfied with the result.

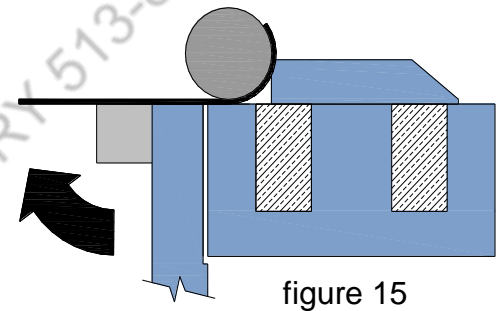
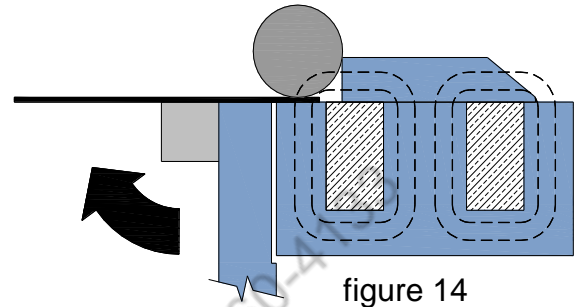

Making a Box with Clamping Bars

1. Using a long clamp bar, initiate the first two bends.
2. Choose and insert one or more of the short clamp bars as shown in (fig. 16) below for the opposite bends. (This method allows for deep depth boxes.)
3. Clamping bars can be laid side by side or pinned together for repeat bending of multiple units.

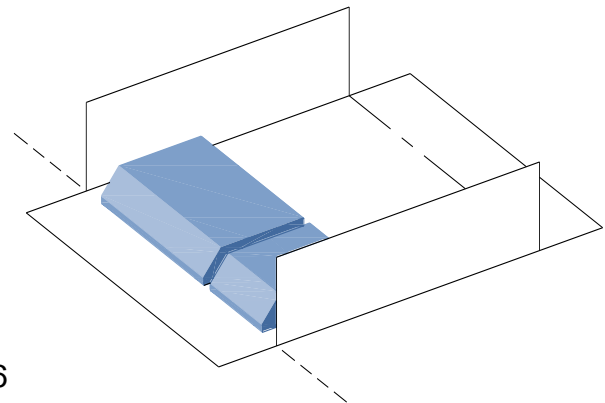
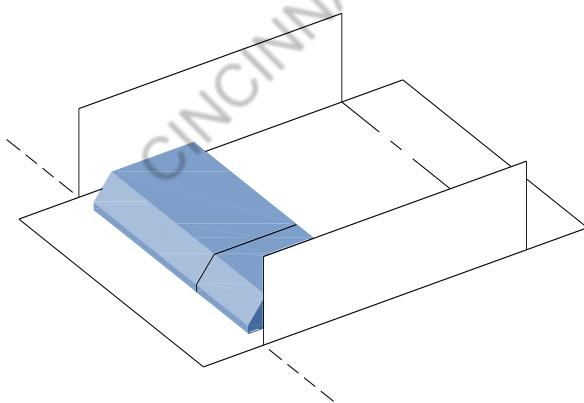

figure 16



Forming Pans With Slotted Clamp Bar

The slotted clamping bar works great for making shallow pans and trays. The entire clamp bar lifts automatically for easy insertion and removal of the piece part.

1. Fold two opposite sides and the corner tabs with the slotted clamp bar. (The slots will NOT affect these bends.)
2. Select two slots that fit the pan for the remaining bends. The edge of the tray should be under the clamp bar and between the selected slots.

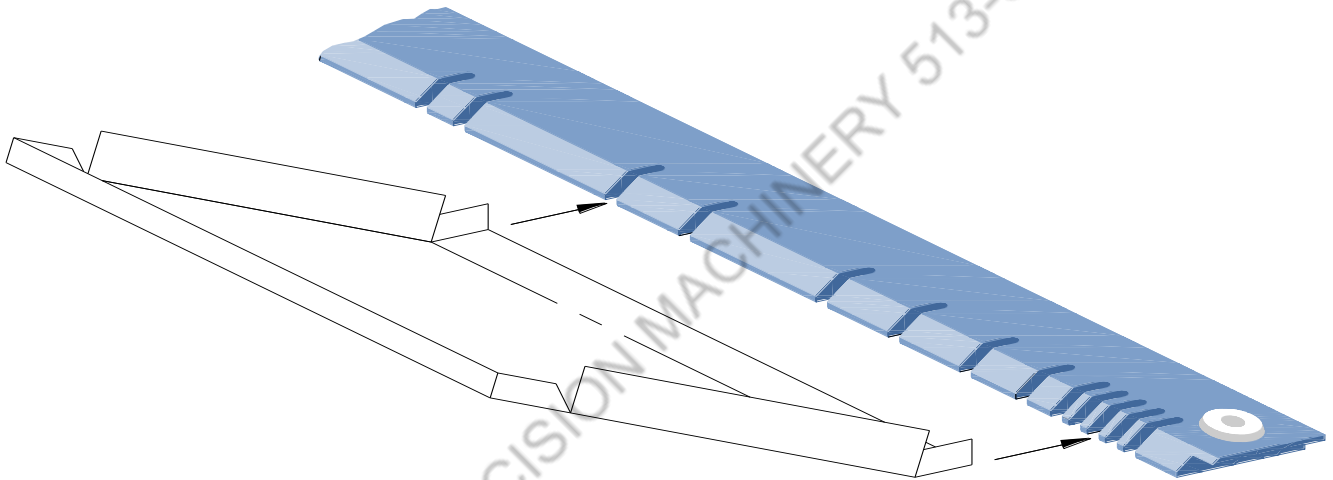

figure 17



LUBRICATION AND MAINTENANCE

⚠ WARNING: Make sure the electrical disconnect is OFF before working on the machine.

Maintenance should be performed on a regular basis by qualified personnel. Always follow proper safety precautions when working on or around any machinery.

- Check daily for any unsafe conditions and fix immediately.
- Check that all nuts and bolts are properly tightened.
- On a weekly basis clean the machine and the area around it.
- Lubricate threaded components and sliding devices.
- Apply rust inhibitive lubricant to all non-painted surfaces.



Note: Proper maintenance can increase the life expectancy of your machine.



figure 18



figure 19



Checking Machine Accuracy

To achieve and maintain accurate bends on the Baileigh BB-4816M magnetic brake, the working surface of the bending beam and the bending edge of the clamp bar need to be straight. Both of these surfaces must also be parallel to each other. This can be checked periodically with a precision straight edge.

Checking the Gap

1. Raise the bending leaf up to a 90° position as shown in (fig. 20).
2. Secure with the locking collar (fig. 21) on the leaf angle indicator arm.
3. Set the gap between the working surface of the bending leaf and the edge of the clamping bar to .039" +/- .008" by using the clamp bar adjusters (fig. 22).
4. The adjuster knobs should be set the same at each end of the clamp bar.

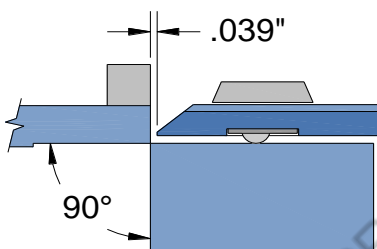

figure 20



figure 21



figure 22



PARTS DIAGRAM

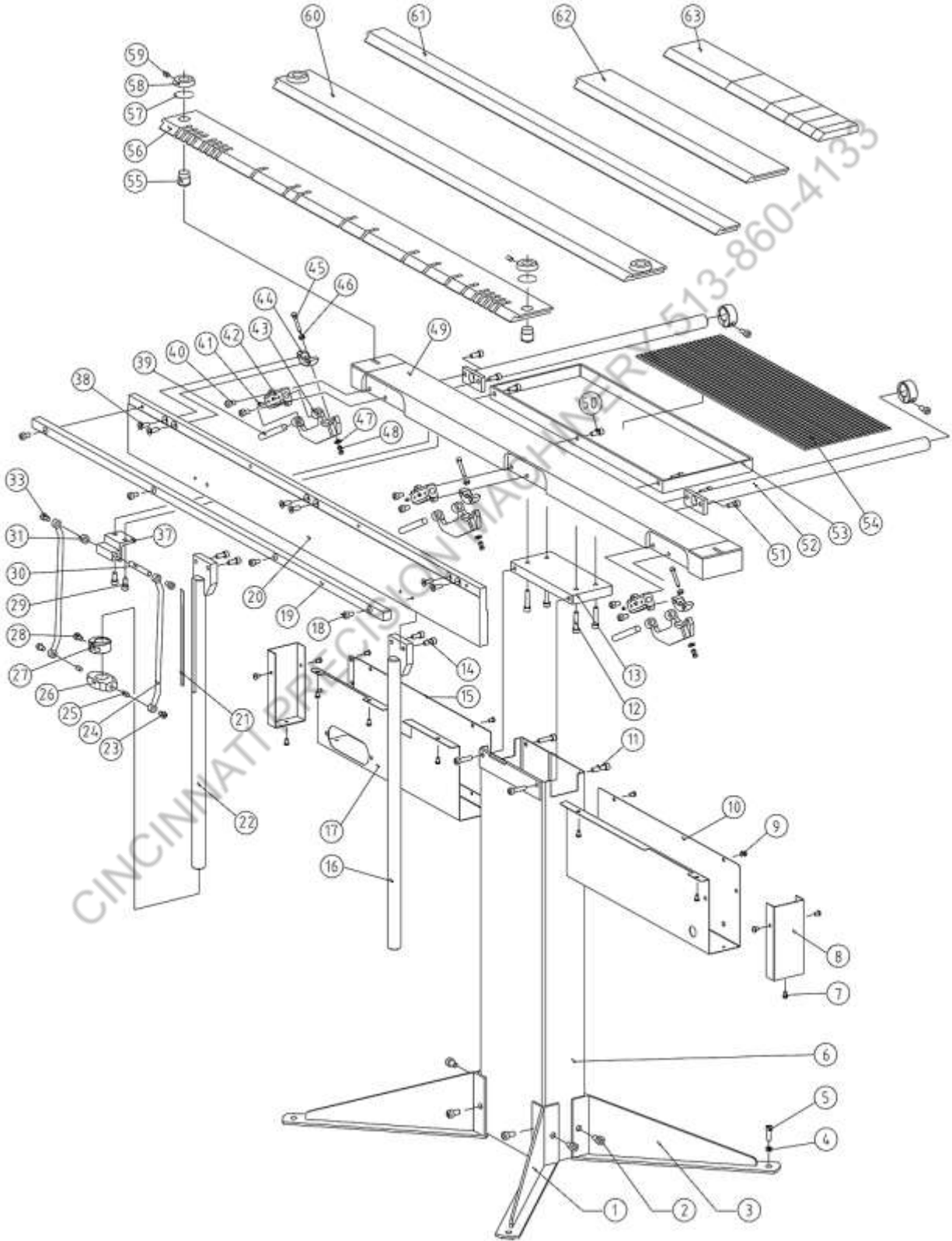



Parts List

Item	Fig. No	Description	Qty.
1	EB1250-011	Front feet	2
2	GB/T70.2	Screw M10X20	8
3	EB1250-012	Back feet	2
4	GB/T6170	Nut M8	2
5	GB/T70.1	Screw M8X25	2
6	EB1250-013	Stand	1
7	GB/T818	Screw M6X12	6
8	EB1250-037	Plate	2
9	GB/T818	Screw M6X12	4
10	EB1250-016	Right Shield	1
11	GB/T70.1	Screw M8X20	4
12	GB/T70.1	Screw M8X30	4
13	EB1250-015	Connect plate	1
14	GB/T70.1	Screw M8X16	4
15	EB1250-30	Cover	1
16	EB1250-014	Right clamp handle	1
17	EB1250-031	Left Shield	1
18	GB/T70.1	Screw M8X20	4
19	EB1250-010	Spoke	1
20	EB1250-006	Bending plate	1
21	EB1250-035	Graduated scale	1
22	EB1250-017	Left clamp handle	1
23	GB/T70.2	Screw M8X20	2
24	EB1250-032	Connect plate	2
25	GB/T77	Screw M8X6	2
26	EB1250-036	Slider	1
27	EB1250-034	Stop Block	3
28	GB/T70.1	Screw M8X20	3
29	GB/T70.1	Screw M8X20	2
30	EB1250-033	Shaft	1
31	EB1250-041	Bushing	1
33	GB/T70.1	Screw M8X20	2
33	GB/T70.1	Screw M8X20	2



Item	Fig. No	Description	Qty.
37	EB1250-027	Angle iron	1
38	GB/T70.3	Screw M8X20	6
39	GB/T119.2	Straight pin 12X100	3
40	GB/T70.1	Screw M8X20	6
41	GB/T77	Screw M5X4	6
42	EB1250-021	Fixed set	3
43	EB1250-022	Hinge body	3
44	EB1250-023	Tee	3
45	EB1250-025	Bolt	3
46	EB1250-024	Ball seat	3
47	GB/T6170	Disc spring 6.2x12.5	1
48	GB/T6170	Nut M6	2
49	EB1250-009	Workbench	1
50	GB/T70.1	Screw M8X16	3
51	GB/T70.1	Screw M8X16	4
52	EB1250-026	Back stop bar	2
53	EB1250-007	Tray	1
54	EB1250-008	Rubber mat	1
55	EB1250-018	Fix shaft	4
56	EB1250-001	Clamp bar 1	1
57	EB1250-020	Spring	4
58	EB1250-019	Indicator dial	4
59	GB/T77	Screw M6X8	4
60	EB1250-002	Clamp bar 2	1
61	EB1250-003	Clamp bar 3	1
62	EB1250-004	Clamp bar 4	1
63	EB1250-005	Clamp bar 5	1



ELECTRICAL COMPONENTS



Shown with cover panel removed

Voltage Tests					
	AC		DC		
Reference Point	Any BLUE Wire		Any BLACK Wire		
Test Point	A	B	C	D	E
Light Clamping Condition	220V AC	25V AC	+25V DC	+25V DC	-300V DC
Full Clamping Condition	220V AC	220V AC	+215V DC	+215V DC	+215V DC



ELECTRICAL SCHEMATIC

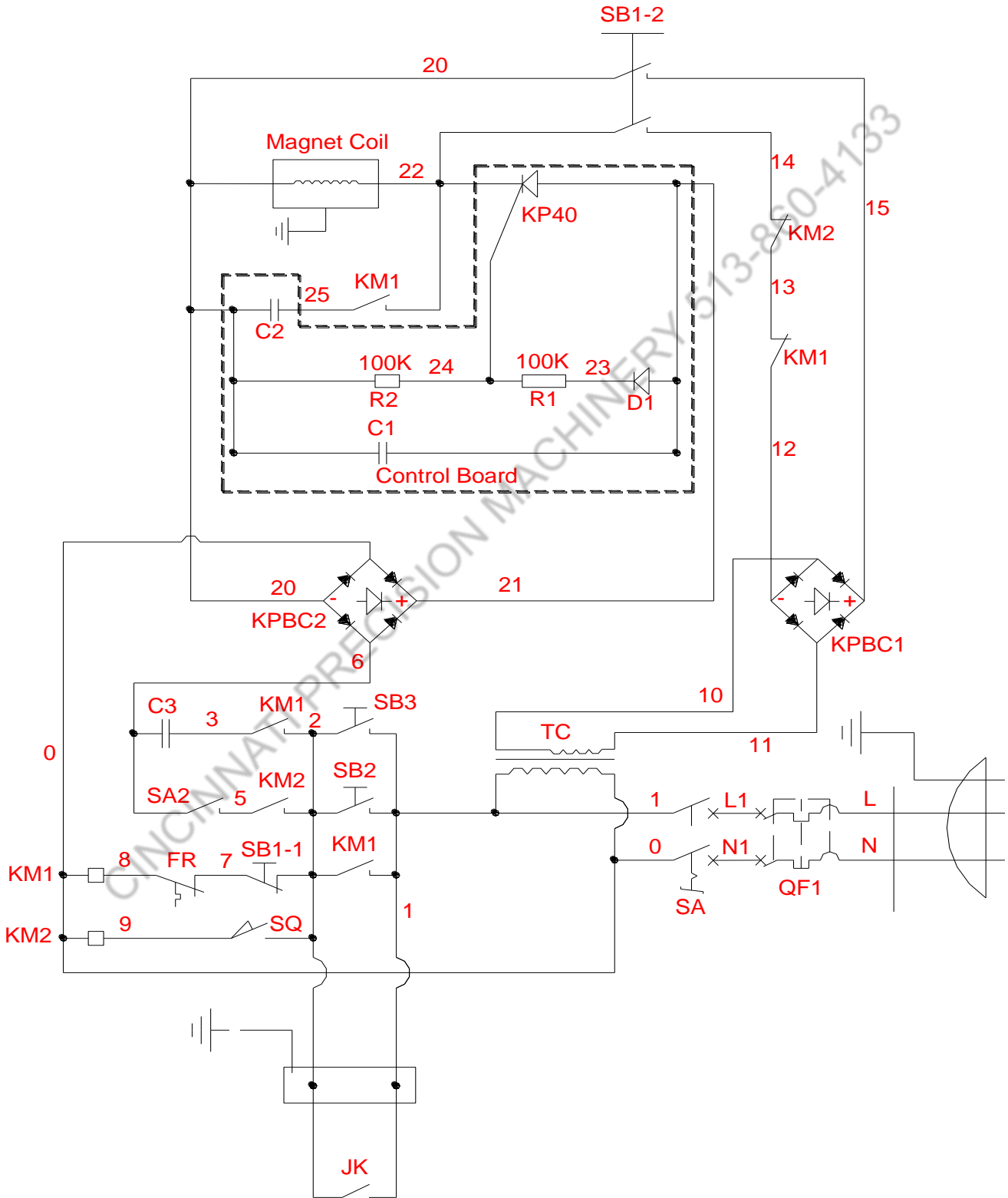



Electrical Components

SB1-1, SB1-2	Red Stop Push Button - NC Contact, NO Contacts, 1-1 Removes power to the magnetic coil circuit, 1-2 activates de-magnetize circuit.
KM1	Contactors, CU-16, Primary coil activation circuit. Creates light clamping pressure.
KM2	Contactors, CU-16, Primary coil activation circuit. Creates full clamping pressure.
CB	Control Board, Holds components C1, C2, C3, D1, KP40, R1, and R2. Controls current to the magnet coil.
KPBC2	Bridge Rectifier – Magnetize
KPBC1	Bridge Rectifier – De-Magnetize
SB3	Green Start Push Button – NO Contact, Right End
SB2	Green Start Push Button – NO Contact, Left End
SA2	Toggle Switch, Clamping Force
FR	Thermal
SQ	Limit Switch, Handle Down
SA	Rocker Switch, Power On/Off
TC	Transformer, Pri.220V, 30VA, 50/60hz – Sec.12V
JK	Foot Pedal Switch - NO Contacts
QF1	2 Pole Breaker



TROUBLESHOOTING

⚠ WARNING: Make sure the electrical disconnect is **OFF** before working on the machine.

FAULT	PROBABLE CAUSE	REMEDY
MACHINE DOES NOT OPERATE	Machine is not plugged in to a live circuit	Have qualified electrician check circuit.
	Bending leaf lifted before start button is pressed	Return bending leaf to lower position and press start button
	Bending leaf micro-switch out of adjustment.	Adjust bending leaf micro-switch to be pressed in when leaf is in the released position.
	Machine power switch is not lit.	Push switch to ON position and make sure light is ON.
	The machine is hot and overheated.	Let the machine cool and try to start again.
	Bending leaf is raised before starting machine.	Do Not lift the bending leaf prior to starting the machine.
	Start pushbutton is faulty.	Try to start with the footswitch, if it starts replace the start switch.
	Loose connection	Check the connector and magnet at the electrical module (Electrician Only)
Clamp bar snaps down on the release of the start button.	Replace the 15 microfarad capacitor.	
Blown fuses or tripped circuit breakers.	Bridge rectifier may be blown.	



Full Clamping Not Operating

If you are not achieving a full clamp, the angle micro switch may not be fully actuated. To check that the angle micro switch is being fully actuated.

- The micro switch can be found on the electrical panel located at the end of the square brass section. The brass section is attached to the angle indicating mechanism.
- To access the electrical panel, the rear cover must be removed.
- When the bending beam is lifted this rotates the brass section which in turn depresses the micro switch. You should be able to hear the micro switch click on and off.
- Failing this, adjust the clutching force. This can be done by ensuring that two M8 cap head screws at either end of the actuator shaft are secured.
- This adjustment should ensure that the actuator rotates and clutches, however, if you are still unable to hear the click, the micro switch may need adjusting.
- The actuator can be adjusted by loosening the screw that secures it, making the adjustment, followed by re-tightening the screw.
- If the micro switch does not click on and off after you have made the above adjustments and rotated the bending beam to the maximum stops, then the switch may be fused and would need to be replaced. Call or email your distributor.

Clamp Bar Not Being Released

This is caused by the failure of the reverse pulse de-magnetizing circuit. Check for sticky contacts on the relay and clean.

The 6.8 power resistor or diodes could be faulty which will have to be replaced.

Problem with the bending of heavy gauge sheet metal

- Ensure that sheet metal thickness is within the specifications of the machine.
- It may occur if narrow lips are being bent over the full length of the machine, please note that the machine is not equipped to do this.
- Should the work piece not be level (i.e. have a welded seam or a joint) it may not be possible to bend the work piece. Ensure that all spaces under the clamp bar are filled with flat pieces of scrap metal.



NOTES

CINCINNATI PRECISION MACHINERY 513-860-4133



NOTES

CINCINNATI PRECISION MACHINERY 513-860-4133



BAILEIGH INDUSTRIAL, INC. 1625 DUFEEK DRIVE MANITOWOC, WI 54220
PHONE: 920. 684. 4990 FAX: 920. 684. 3944
www.baileigh.com

BAILEIGH INDUSTRIAL, INC. 1455 S. CAMPUS AVENUE ONTARIO, CA 91761
PHONE: 920. 684. 4990 FAX: 920. 684. 3944

BAILEIGH INDUSTRIAL LTD. UNIT D SWIFT POINT
SWIFT VALLEY INDUSTRIAL ESTATE, RUGBY
WEST MIDLANDS, CV21 1QH UNITED KINGDOM
PHONE: +44 (0)24 7661 9267 FAX: +44 (0)24 7661 9276
WWW.BAILEIGH.CO.UK

BAILEIGH INDUSTRIAL PTY. LTD.
P.O Box 1573, 126 MELROSE DRIVE TULLAMARINE,
VIC 3043 AUSTRALIA
PHONE: 011 61 383 743 888
WWW.BAILEIGH.COM.AU